

# INNOVATION MAKES EXCELLENT

有 | 跨 | 越 | 才 | 有 | 卓 | 越

## 压力/差压变送器



联系人: 姚经理: 13685509377 Email: 115192082@qq.com

# 企业简介

Brief Introduction

长江宛如一条巨龙奔腾不息，在长江之滨的天长市有这样一颗璀璨的明珠——安徽天康（集团）股份有限公司，在经历了岁月的历练与洗礼后愈发闪耀夺目。

安徽天康（集团）股份有限公司创建于1974年，总部位于“长三角”经济圈核心区域一天长市，是中国民营企业制造业500强企业、中国电子信息百强企业、国家级守合同重信用企业、国家高新技术企业、安徽省依法纳税先进企业、银行资信AAA级企业、中国仪表行业十强企业、中国电线电缆十强企业、安徽省重点骨干企业、“全国五一劳动奖状”获得者等荣誉。

天康集团历经四十年的蓬勃发展，已形成集仪器仪表、光电缆、医疗卫生、锂电池等跨行业、多元化的集团公司，下属子公司达二十余家。旗下产品凭借良好的质量与服务，被广泛应用于石油、电力、化工、通讯、卫生、新能源汽车及储能等行业和领域。

作为皖东经济最具活力与贡献的骨干企业之一，天康集团以“追求卓越，缔造满意”为目标，依托一流的产品、一流的管理、一流的服务，不仅在国内市场中赢得了广泛赞誉；在国际市场中，天康产品远销欧洲、非洲、亚洲等46个国家和地区。

天康集团在发展中逐步形成了独特的品牌文化及着眼全球的经营部局，全力塑造“高科技、高品质、国际化”的品牌形象。始终秉承“有跨越才有卓越”的天康精神，在创建和谐企业的基础上，引进国际先进的构架与模式，组织企业的生产经营管理体系。在积极参与国际化竞争的基础上，不断把握市场发展脉搏，寻求经济战略联盟，与全球伙伴共同发展与进步。如今天康人将全新的投入化为无私的奉献，与世界共同发展，与人类一起进步。

联系人：姚经理：13685509377 Email: 115192082@qq.com





Yangtze River like a dragon Pentium, there is such a shining pearl - Anhui Tiakang (Group) Co., Ltd. in Tianchang City in the Yangtze River foreshore, in after years of experience and baptism increasingly shining brightly.

Anhui Tiakang (Group) Co., Ltd. created in 1974, the headquarters is located in the "Yangtze River Delta" economic circle core area - Tianchang City, is China's private enterprises in the manufacturing industry 500 strong enterprises, China's electronic information hundred enterprises, state-level keep contract re credit enterprise, national new and high technology enterprise, Anhui Province tax law advanced enterprises, bank credit AAA level enterprise, China instrument industry ten strong enterprises, top ten enterprises in the Chinese wire and cable, Anhui province key enterprises, "national labor certificate" get "and other honorary.

After forty years of vigorous development, the group has formed a set of instruments, optical cable, medical and health, lithium batteries, such as cross industry, diversified group companies, subsidiaries of more than twenty. Products with good quality and service, is widely used in oil, electricity, chemicals, communications, health, new energy vehicles and energy storage and other industries and areas.

As one of the backbone enterprises in Anhui east economy the most vitality and contribution, tecon group to "the pursuit of excellence, creating satisfaction" as the goal, relying on the first-class products, first-class management, first-class service, not only in the domestic market won wide acclaim; in the international market, the day Kang products are exported to 46 countries and regions, including Europe, Africa, and Asia.

Tecon group in the developing gradually formed a unique brand culture and focus on global business department bureau, spare no effort to shape the brand image of "high-tech, high-quality, internationalization". Always adhering to the "excellence," the spirit of Tiakang across only, to create the basis for a harmonious enterprise, the introduction of international advanced framework and patterns, organization of production management system. Actively participate in the international competition, and continue to grasp the pulse of the market development, to seek economic and strategic alliances, and global partners to develop and progress. Such as today, the people will be a new investment into the selfless dedication, and the common development of the world, together with the progress of mankind.

联系人：姚经理：13685509377 Email: 115192082@qq.com



# 目 录

## CONTENTS

---

---

TK3051系列压力变送器 Series Pressure Transmitter.....	1
TK3051A/B-H型高温高压变送器 TK3051A/B-H High Temperature and Pressure Transmitter.....	12
TK3051A/B-T型表压与绝压变送器 TK3051A/B-T Gauge Pressure and Absolute Pressure Transmitter.....	15
TK3051A/B-C型差压、表压与绝压变送器 TK3051A/B-C Differential Pressure, Gauge Pressure and Absolute Pressure Transmitter.....	16
TK3051L型液位变送器 TK3051L Liquid Level Transmitter.....	18
1199远传膜片密封件系统 Remote Transmitting Sealing System.....	23
TK3051A/B-F卫生型压力变送器 TK3051F Sanitary Pressure Transmitter.....	29
TK3051A/B-P高温防腐型压力变送器 TK3051P High Temperature Anti-corrosive Pressrue Transmitter.....	34
TK208,TK316系列扩散硅压力变送器 TK208, TK316 Series Diffused Silicon Pressure Transmitter.....	38
TK型扩散硅压力变送器选型表 TK Series Diffused Silicon Pressure Transmitter Selection Table.....	39
TK静压式导压式液位变送器 TK Static Pressure Pressure Guiding Liquid Level Transmitter.....	40
TK301一体化浓度/密度变送器 TK 301 Integrated Concentration/Density Transmitter.....	43
TK6800电动压差式液位变送器 TK6800 Electric Pressure Differntial Liquid Level Transmitter.....	45



# TK3051A/B系列压力变送器 Series Pressure Transmitter



## 一、概要

TK3051A/B系列压力变送器用于工业过程全系列差压、压力、绝对压力的测量，具有模拟或数字输信号。广泛应用于石油、化工、电力、食品、造纸、市政工程等行业。

### TK3051A/B系列产品

Cd系列差压变送器  
Cg系列压力变送器  
Ca系列绝压变送器  
L系列液位变送器  
H系列高温高压型压力变送器  
T系列表压与绝压变送器  
F系列卫生型压力变送器  
P系列高温防腐型压力变送器

### 主要技术指标

量程比：100:1 ~ 20:1  
精度高：±0.05~0.2  
智能：HART现场总线协议  
总线：PROF1BUS-PS  
低温漂：数字温度传感器自动补偿  
规格全：-100Kpa~120Mpa  
耐腐蚀：提供316L、哈氏合金、钽等  
耐压性能好：常规14MPa  
高静压32MPa  
防爆：本安型(iaIICT4/T6)  
          隔爆型(dIICT4/T6)

### 性能

工业领域中最优的总体性能±0.15%，令回路性能最优化  
五年稳定性±0.15%，可大大降低校验和维护费用  
更快的动态响应，可降低过程的可变性  
引进技术可实现全面测量方案  
本地/外部：零点/量程调整

## I. General

TK3051 series pressure transmitters with analog or digital signal are used to measure the full series of differential pressure, pressure, absolute pressure of industrial process in industries like petroleum, chemistry, electric power, food, paper making and municipal works.

### TK3051 series products

CD series differential pressure transmitters  
CG series pressure transmitters  
CA series absolute pressure transmitters  
L series liquid level transmitters  
H series high temperature and high pressure pressure transmitters  
T series gauge pressure and absolute pressure transmitters  
F series sanitation pressure transmitters  
P series high temperature anti-corrosive pressure transmitters

### Main technical index

Range ratio: 40:1  
High accuracy: ±0.1%range  
Intelligent: HART field bus protocol  
BUS: PROF1BUS-PS  
Low temperature drift: automatic compensation for digital temperature sensor  
Full size: -100pa~120Mpa  
Corrosion resistant: provide 316L, Hastelloy, tantalum  
Good pressure resistant performance: normal 14MPa  
High static pressure 32MPa  
Anti-explosion: intrinsic safety type (iaIICT4/T6)  
                  explosion suppression type (dIICT4/T6)

### Performance

Optimum overall performance in the industrial filed ±0.15%, making the circuit performance optimal  
Five year stability of ±0.15%, greatly reducing the inspection and maintenance cost  
Faster dynamic response, reducing the variability of the process  
The introduced technology is able to realize the overall measurement solution  
Local/external: zero point/scale adjustment

联系人：姚经理：13685509377 Email: 115192082@qq.com

## 全面解决方案

小巧而质轻的设计，具有最佳的性能，高量程比对现场的库存要求最低

可采用一体化安装阀组，可节约安装费，因为公司可将变送器和阀组在工厂一体化装配，并在工厂完成了泄漏检查和校验

1199“调整型”直接安装式远传可节约采购和安装费用20%以上，性能提高超过10%，响应时间加快10%以上

主要元件均采用进口  
具有国内外最新压力变送器的结构优点和良好性能

通用型安装结构及规格，替代能力强，是新一代压力测量的优秀换代产品

## Overall solution

Delicate and light design with optimal performance, high range ratio requires the minimum of inventory on site.

Integrated installation valves can be adopted to save money since the company can assemble the transmitters and valves at the plant in an integrated way and the leakage check and test are finished on site.

With the 1199 "adjustment type" direct installed remote signaling, more than 20% of the purchase and installation expense can be saved, the performance is improved by more than 10% and the response time is more than 10% faster.

The main elements are imported.

With structure advantages and good performance of latest pressure transmitter at home and abroad

General type of installation structure and size, highly replaceable and it is new generation of excellent replacement product for pressure measurement.

## 二、产品介绍

### 3051C型差压，表压与绝压变送器

性能优异：精度0.05%~0.2%，量程比100:1~20:1

差压：校验量程从0.1kPa至21MPa

表压：校验量程从0.12kPa至21MPa

绝压：校验量程从1.5kPa至21MPa

过程隔离膜片：不锈钢，哈氏合金，蒙乃尔，钽（仅限CD，CG）及镀金蒙乃尔，镀金不锈钢设计  
小巧、坚固而质轻，易于安装 复合量程（仅限CD，CG），可测量负压

## II. Product Introduction

### 3051C differential pressure, gauge pressure and absolute pressure transmitter

Excellent performance: accuracy 0.1%, range ratio: 40:1  
Differential pressure: the inspection range from 0.1kPa to 21MPa

Gauge pressure: the inspection range from 0.12kPa to 21MPa

Absolute pressure: the inspection range from 1.5kPa to 21MPa

Process isolation diaphragm: stainless steel, hastelloy, Monel, tantalum (only for CD, CG) and gold plated Monel, gold plated stainless steel.

Compact design, solid and light in weight, easy to install

Compound range (only for CD, CG), able to measure the negative pressure

### 3051T型差压，表压与绝压变送器

性能优异：精度0.05%~0.2%

绝压：校验量程从0.12kPa至120MPa

表压：校验量程从0.12kPa至120MPa

不锈钢与哈氏合金C过程隔离膜片

灌注液：硅油与惰性液 可选DIN和与压力反应罐相配的过程相连 复合量程（仅限TG），可测量负压 最大过压达1000倍以上

### 3051T differential pressure, gauge pressure and absolute pressure transmitter

Excellent performance: accuracy 0.1%

Absolute pressure: the inspection range from 0.12kPa to 120MPa

Gauge pressure: the inspection range from 0.12kPa to 120MPa

Stainless steel and hastelloy C process isolation diaphragm

Filling liquid: silicon oil and inertia fluid

Optional DIN and connected to process matching pressure reaction tank

Compound range (only for TG), able to measure negative pressure

Maximum overpressure over 1000 times

### 3051L型液位变送器

校验量程从0.4kPa至2.1MPa

平膜片式，2-，4-，与6英寸伸出膜片

多种灌注液可选，满足不同应用场合的要求

小巧而质轻，易于安装与维护

接液件材料：不锈钢，哈氏合金和钽

### 3051L liquid level transmitter

Liquid level measuring accuracy up to 0.1% ,0.2%

Inspection range from 0.4kPa to 2.1MPa

Flat diaphragm type, 2-, 4-, and 6 inch projected diaphragm

Multiple kinds of filling liquid optional, able to meet the requirements of different application fields

Delicate and light in weight, easy to install and maintain

Liquid connection material: stainless steel, hastelloy and tantalum



### 三、产品说明

#### 传感膜头

3051C型采用先进技术及生产线制造的高品质传感器。传感器与过程介质和外部环境保持机械、电气及热隔离。传感器远离过程法兰，移至电子外壳的颈部，可实现机械隔离和热隔离。该设计使传感器不与过程热源直接接触，并释放了传感器杯体上的机械应力，可提高静压性能。

玻璃密封的压力输送管与传感器杯体绝缘安装，保证了电气绝缘，可提高电子线路的灵活性、性能与耐瞬变电压保护的能力。

3051C型传感膜头还进行温度测量，用于补偿温度影响。

在工厂的特性化过程中，所有传感器都经受了整个工作范围内的压力与温度循环测试。根据由此得来的数据产生修正系数，然后将系数贮存于传感膜头的内存中，从而可保证变送器运行过程中能精确地进行信号修正。

该种传感膜头的内存也可帮助加快维修过程。因为所有膜头的特性值都贮存在膜头中，所以可直接更换线路板而无需重新校验或拆下独立的贮存。使用HART手操器可以方便地对3051型进行组态。组态由两部分组成。首先，设定变送器的工作参数，包括：存修正系数的PROM。

传感膜头内还有线路板，它将输入的电容与温度信号直接转换成可供电子板模块进一步处理的数字化信号。

#### 电子线路板

电子板采用专用集成电路(ASIC)与表面封装技术。该板接收来自传感膜头的数字输入信号及其修正系数，然后对信号进行修正与线性化。电子板模块的输出部分将数字信号转为模拟输出，并与HART手操器进行通讯。标准的模拟型输出为4-20mA。

可选液晶表头插在电子板上，以压力、流量或液位工程单位或模拟量程值百分比显示数字输出，变送器均可选用液晶表头。

#### 数据存贮

组态数据存贮于变送器电子板模块的永久性EEPROM存贮器中。变送器掉电后，数据仍保存，故而上电后变送器能立即工作。

#### 数/模转换与信号传送

过程变量以数字式数据存贮，可以进行精确地修正和工程单位的转换。信号经修正后的数据转换为模拟输出信号。HART手操器可以直接以数据信号方式存取传感器读数，不经过数/模转换以得到更高精度。

### III. Product Description

#### Sensing film head

3051C is high quality sensor manufactured with advanced technology and production line. The sensor is isolated mechanically, electrically and thermally from process medium and external environment. The sensor is away from the process flange, moved to the neck of the external electronic shell and able to realize the mechanical and thermal isolation. With this design, the sensor does not contact directly the process thermal source and the mechanical stress on the sensor cup is released so that the static pressure performance can be improved.

The pressure transportation pipeline sealed with glass is installed with sensor cup in insulated way, which guarantees the electric insulation, improves the flexibility and performance of electronic circuit and the protection ability to withstand transient voltage.

3051C sensing film head can also be used to measure the temperature and compensate for the temperature influence.

During the plant characterization process, all the sensors experience the pressure and temperature cycle test within the whole operation range. The correction coefficient is produced based on the obtained data and then the coefficient is stored in the memory of the sensing film head so as to guarantee that the transmitter can make correct signal correction during the operation.

The memory of this kind of sensing film head can also help facilitate the maintenance. Since all the characteristic value of the film head is stored in the film head, the circuit board can be replaced directly without re-calibration or removing the independent storage. It is easy to configure 3051 type with HART communicator. The configuration consists of two parts. Firstly, set the working parameters of the transmitter, including: store the PROM of correction coefficient.

There is also circuit board in the film sensing head which converts directly the input capacitance and temperature signal to the digital signal which can be further processed by the electronic board module.

#### Electronic circuit board

The electronic circuit board uses special integrated circuit (ASIC) and surface mount technology. This board receives the digital input signal from the sensing film head and its correction coefficient and then make correction and linearization for the signal. The output part of the electronic board module converts the digital signal to analog output and communicates with the HART. Standard analog output is 4-20mA.

Optional liquid crystal meter is inserted on the electronic board which shows the digital output with pressure, flow or liquid level engineering unit or analog range percentage. The transmitter can use liquid crystal meter.

#### Data storage

The configuration data is stored in the permanent EEPROM memory of the electronic board module of the transmitter. After the transmitter loses power, the data is still kept, thus the transmitter can start work immediately after power on.

#### D/A conversion and signal transmitting

The process variable is stored in the form of digital data which can correct accurately the conversion with engineering unit. The signal is converted to analog output signal via converted data. HART device can access directly the reading of sensor in the form of the digital signal and get higher accuracy without A/D conversion.

## 通讯格式

3051型采用HART协议进行通讯，该协议使用了工业标准Bell202频移调制(FSK)技术。在模拟输出上叠加高频信号可以进行远程通讯。采用该技术，能在不影响回路完整性的情况下，实现同时通讯和输出。

## 软件功能

HART协议使用户可以容易地使用3051型的组态，测试与具体设定的功能。

## 组态

使用HART手操器可以方便地对3051型进行组态。组态由两部分组成。首先，设定变送器的工作参数，包括：零点与量程设定点。

## 线性或平方根输出

阻尼

## 工程单位选择

其次，可将信息性数据输入变送器，以便对变送器进行识别与物理描述，包括：

工位号：8个字母数字字符  
描述符：16个字母数字字符  
日期  
一体化表头安装  
法兰类型 排液 / 排气  
阀材料 O型环材料  
远传信息

除以上讨论的可组态参数外，3051型软件中还包含一些用户不可变更的信息：变送器类型，传感器极限值，最小量程，灌充液，隔离膜片材料，膜头系列号及变送器软件版本号。

## 测试

3051型可以进行连续自检。当出现问题时，变送器将激活用户选定的模拟输出报警。HART手操器可以查询变送器，确定问题所在。变送器向手操器输出特定信息，以识别问题，从而快速而便捷地采取维修措施。若操作员确认是回路有问题，可以让变送器给出特定输出，以供回路测试。

## 具体设定

在变送器初始化阶段和数字电子板维护时需进行具体设定。它允许对传感器与模拟输出进行微调，以符合工厂压力标准。此外，特性化功能令用户可以防止模拟输出设定点被意外或故意调整。

## 四、选项

液晶表头  
M5数字表头，液晶显示  
直接显示数字数据，精度更高  
按用户要求显示流量、液位、体积或压力单位  
显示诊断信息，用于现场故障检修  
可旋转90°，便于安装

## Communication format

3051 type adopts HART protocol for communication which uses industrial standard Bell202 frequency shifting keying (FSK) technology. High frequency signal is superposed on the analog output to make remote communication. This technology enables communication and output at the same time without affecting the integrity of the circuit.

## Software function

HART protocol enables the user to use easily the 3051 type configuration and test the specifically set functions.

## Configuration

It is easy to configure the 3051 type with HART communicator. The configuration consists of two parts. Firstly, set the working parameters of the transmitter, including: zero point and range set points

## Linear or square root output

Delay time

## Selection of engineering unit

Secondly, the information data can be input to the transmitter so that the transmitter can make recognition and physical description, including:  
Work position No.: character of eight letters and number  
Descriptor: character of sixteen letters and number  
Date  
Integrated meter installation  
Flange type liquid/air drain  
Valve material O-ring material  
Remote transmitting information

Apart from the configurable parameters above, there is also some information that the user can not change in the 3051 type software: transmitter type, limit value of the sensor, minimum range, filling liquid, material of isolation diaphragm, film head type and version of transmitter software.

## Test

3051 type can make continuous self-check. When there is problem, the transmitter will activate the analog output alarm selected by the user. HART device can inquire about the transmitter and determine the problems. The transmitter outputs specific information to the HART device so as to recognize the problem and take maintenance measures rapidly and conveniently. When the operator confirms that there is problem with circuit, he can let the transmitter give specific output to test the circuit.

## Specific setting

Specific setting is required during initialization of transmitter and maintenance of digital electronic board. It allows the fine tuning of the sensor and analog output so as to meet the pressure standard of the plant. Besides, characterized function enables the user to prevent the analog output setting point from accident or intentional adjustment.

## IV. Option

Liquid crystal meter  
M5 digital meter, liquid crystal display  
Direct display of digital data, higher accuracy  
Display the flow, liquid level, volume or pressure unit as per customer requirements  
Display the diagnosis information, for repair of fault on site  
It can turn 90 degrees, easy to install

联系人：姚经理：13685509377 Email: 115192082@qq.com



本机量程与零点调整  
作为标准配制，变送器带有本机量程与零点调整按钮  
非交互式外部零点与量程调整，易于校验  
按钮代替标准电位计进行调整，以实现最佳性能

耐瞬变电压保护  
一体化耐瞬变电压保护端子块

法兰与接头用螺栓  
法兰与接头可配用不同材料的螺栓  
标准材料为电镀碳钢

## 五、选项

### 性能指标

总体性能是基于参考精度，环境温度影响与量程静压影响的综合误差。

3051C型(量程4-9)、3051T

### 参数精度

±0.1%量程

### 总体性能提高

±0.15%量程，在±500F(28℃)温度变化，最大6.9MPa静压(仅限CD)，1:1至5:1量程比的条件下。

### 稳定性提高

±0.125%URL，5年，在温度变化±500F(28℃)，静压最大为6.9MPa条件下。

### 动态性能

总的响应时间(Td+Tc)  
100毫秒(HART输出)

3051CD型，微差压(量程2-3)

### 参考精度

±0.10%量程

### 稳定性

±0.2%URL，1年

### 参考精度

±1%量程

3051 H型—高温、高压

### 稳定性

±0.2%URL，1年

## 具体性能指标

(零基量程，参考条件，硅油充液，316不锈钢隔离膜片，20mA模拟输出，数字微调值等于量程设定点值。)

### 参考精度

(参考精度包括迟滞性、基于端子的线性、设定能力和重复性。)

### 3051CD量程4-9和3051CG

±0.1%量程

超过10:1的量程，精度=

±[0.015+0.005( $\frac{\text{URL}}{\text{量程}}$ )]%量程

Range and zero point adjustment of this machine.

As standard make-up, the transmitter has the adjustment button for range and zero point of this machine.

Non-interactive external zero point and range adjustment, easy to inspect.

Button replacing the standard potentiometer to make adjustment to realize the optimum performance.

Resistant to transient voltage protection.

Integrated protection terminal block resistant to transient voltage.

Flange and joint bolts.

Bolts of different materials can be used for flange and joint.

The standard material is galvanized carbon steel.

## IV. Specification

### Performance index

The overall performance is the comprehensive error based on reference accuracy, ambient temperature influence and range static pressure influence.

3051C (range type4-9), 3051T

### Reference accuracy

±0.1% range

### Overall performance improvement

±0.15% range, under the condition of temperature change ±500F(28℃), maximum static pressure of 6.9MPa (only for CD) and range ratio 1:1 to 5:1.

### Stability is improved

±0.125%URL, five years, under the condition of temperature change ±500F(28℃) and maximum static pressure of 6.9MPa.

### Dynamic performance

Total response time (Td+Tc)  
100 millisecond (HART output)

3051CD type, micro differential pressure (range 2-3)

### Reference accuracy

±0.10% range

### Stability

±0.2%URL, one year

### Reference accuracy

±0.1% range

3051 H type-high temperature, high pressure

### Stability

±0.2%URL, one year

## Specific performance index

(zero base range, reference conditions, silicon oil filling, 316 stainless steel isolation diaphragm, 20mA analog output, digital micro adjustment value equals the setting point value of the range).

### Reference accuracy

(the reference accuracy includes the hysteresis, linearity based on terminal, setting ability and repeatability.)

### 3051CD range 4-9 and 3051CG

±0.1% range

Range exceeding 10:1, accuracy=

±[0.015+0.005 (URL/Milestone)]% range

联系人：姚经理：13685509377 Email: 115192082@qq.com

### 3051CD量程3

±0.10%量程  
超过15:1的量程, 精度=  
 $\pm [0.025+0.005 \left(\frac{\text{URL}}{\text{里程}}\right)]\%$ 量程

### 3051CD量程2

±0.10%量程  
超过2:1的量程

### 3051T / CA量程4-10

±0.1%量程  
超过10:1的量程, 精度=  
 $\pm [0.1 \left(\frac{\text{URL}}{\text{里程}}\right)]\%$ 量程

### 3051T量程3

±0.1%量程  
超过10:1的量程, 精度=  
 $\pm [0.1 \left(\frac{\text{URL}}{\text{里程}}\right)]\%$ 量程

### 3051L

±0.10%量程  
超过10:1的量程, 精度=  
 $\pm [0.025+0.005 \left(\frac{\text{URL}}{\text{里程}}\right)]\%$ 量程

### 环境温度影响(每50° F(28°C)影响) 3051 CD / CG

1:1至5:1: ±(0.0125%URL+0.0625%量程)  
5:1至40:1: ±(0.025%URL+0.125%量程)  
量程0: ±(0.25%URL+0.05%量程)  
量程1: ±(0.1%URL+0.25%量程)

### 3051T和3051CA

1:1至40:1: ±(0.025%URL+0.125%量程)  
3051T量程5: ±(0.1%URL+0.15%量程)

### 3051T量程1

1:1至40:1: ±(0.025%URL+0.125%量程)

### 静压每变化6.9MPa的影响

#### 3051CD

#### 零点误差(可标定消除)

静压从2至4, 13.7MPa时, ±0.05%URL  
静压大于13.7MPa时, 见用户手册  
量程2: ±0.125%量程/689kPa  
量程3: ±0.25%URL

### 参考精度

量程4-5 ±0.1%读数  
量程2: ±0.15%量程/689kPa  
量程3: ±0.4%读数

### 动态性能

延迟时间和刷新速率适用于所有型号和量程,  
仅限模拟输出。  
延迟时间 (Td): 45毫秒(名义值)

### 刷新速率: 22 闪 / 秒

### 总的 影响时间 (Td+Tc):

### 3051C 4-20mA/HART

里程4-9: 100毫秒  
里程3: 255毫秒  
里程2: 700毫秒

### 3051T

里程3-10: 100毫秒

### 3051CD range 3

±0.10% range  
Range exceeding 15:1, accuracy=  
 $\pm [0.025+0.005 (\text{URL/Milestone})]\%$  range

### 3051CD range 2

±0.10% range  
Range exceeding 2:1

### 3051T / CA range 4-10

±0.1% range  
Range exceeding 10:1, accuracy=  
 $\pm [0.1 (\text{URL/Milestone})]\%$  range

### 3051T range 3

±0.1% range  
Range exceeding 10:1, accuracy=  
 $\pm [0.1 (\text{URL/Milestone})]\%$  range

### 3051L

±0.10% range  
Range exceeding 10:1, accuracy=  
 $\pm [0.025+0.005 (\text{URL/Milestone})]\%$  range

### Ambient temperature influence (influence of each 50° F(28°C))

#### 3051 CD / CG

1:1 to 5:1: ±(0.0125%URL+0.0625% range)  
5:1 to 40:1: ±(0.025%URL+0.125% range)  
Range 0: ±(0.25%URL+0.05% range)  
Range 1: ±(0.1%URL+0.25% range)

#### 3051T and 3051CA

1:1 to 40:1: ±(0.025%URL+0.125% range)  
3051T range 5: ±(0.1%URL+0.15% range)

#### 3051T range 1

1:1 to 40:1: ±(0.025%URL+0.125% range)

#### 3051T and 3051CA

#### 3051CD

#### Zero point error (can calibrate to eliminate)

When the static pressure from 2 to 4, 13.7MPa, ±0.05%URL  
When static pressure larger than 13.7MPa, see user manual  
Range 2: ±0.125% range/689kPa  
Range: 3: ±0.25%URL

#### Range error

Range 4-5 ±0.1% reading  
Range 2: ±0.15% range/689kPa  
Range 3: ±0.4% reading

### Dynamic performance

The delay time and refresh rate applicable to all models and range, only for analog output  
Delay time (Td): 45 milliseconds (nominal value)

### Refresh rate: 22 flashes/second

### Total influence time (Td+Tc):

### 3051C 4-20mA/HART

Range 4-9: 100 milliseconds  
Range 3: 255 milliseconds  
Range: 2: 700 milliseconds

### 3051T

Range 3-10: 100 milliseconds





图1. 典型的智能变送器的响应时间 Fig 1. Response time of typical intelligent transmitter

### 安装位置影响 3051T

零点最多漂移 $\pm 0.31\text{kPa}$ , 可修正掉。无量程影响。

### 3051L

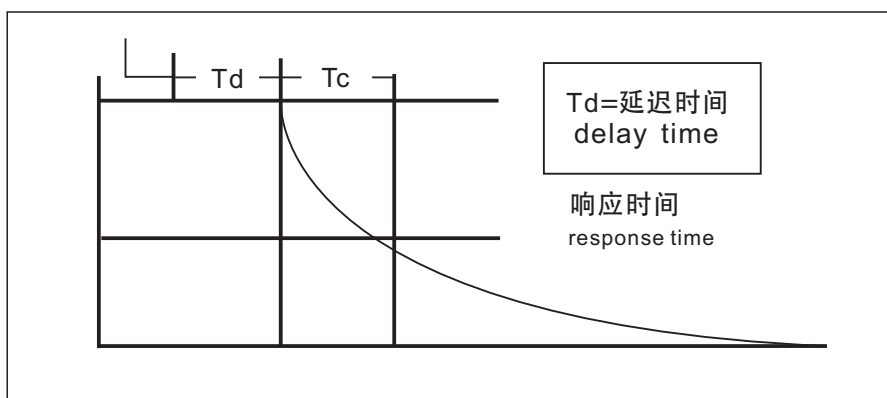
若液位膜片处于垂直位置, 零点至多漂移 $0.25\text{kPa}$ 。

若液位膜片处于水平位置, 零点至多漂移 $1.25\text{kPa}$ 加上伸出装置的伸出长度。所有零点漂移均可修正掉。无量程影响。

### 3051T/CA

零点最多漂移 $0.6\text{kPa}$ , 可修正掉。无量程影响。

### 振动影响 所有型号

只考虑谐振频率影响, 其它振动影响均忽略不计。

在谐振下, 与管道轴向成任意角度的方向施加 $15\text{--}2000\text{Hz}$ 的振动进行测试, 振动影响小于 $\pm 0.1\% \text{URL/g}$ 。

### 电源影响 所有型号

小于 $\pm 0.01\%$ 量程/伏

### 射频干扰影响 所有型号

小于 $\pm 0.1\%$ 量程,  $20\text{至}1000\text{MHz}$ , 场强达到 $30\text{伏/米}$

### 耐瞬变电压保护(选项代码T1)

#### 所有型号

$6\text{kV}$ 峰值 ( $0.5\ \mu\text{s}\text{--}100\text{kHz}$ )

$3\text{kV}$ 峰值 ( $8\times 20\text{ms}$ )

$6\text{kV}$ 峰值 ( $12\times 50\text{ms}$ );  $5\text{kV}$ 峰值,  $1.25\text{MHz}$ 波形

### 综合性能指标

响应时间:  $<1\text{纳秒}$

浪涌峰值电流:  $5,000\text{安培}$ , 对外壳

瞬变峰值电压:  $100\text{VDC}$

回路阻抗:  $<25\ \Omega$

注意:

按ASME Z210.1 (ANSI) 在 $68\text{--}0\text{F}$  ( $20^\circ\text{C}$ ) 下进行校验

### Installation position influence 3051T

Maximum zero point drifting  $\pm 0.31\text{kPa}$ , can be corrected. No range influence.

### 3051L

When the liquid level diaphragm is in the vertical position, the maximum zero point drifting is  $0.25\text{kPa}$ .

When the liquid level diaphragm is at the horizontal position, the maximum zero point drifting is  $1.25\text{kPa}$  plus the protruding length of the protruding device. All the zero point drifting can be corrected. No range influence.

### 3051T/CA

The maximum zero point drifting is  $0.6\text{kPa}$ , it can be corrected. No range influence.

### Vibration influence All the model

Only the resonance frequency influence is considered and other vibration influence is neglected.

Under the resonance, apply  $15\text{--}2000\text{Hz}$  of vibration in the direction of any angle with the axial direction of the pipeline to conduct the test. The vibration influence is smaller than  $\pm 0.1\% \text{URL/g}$ .

### Power supply influence All the model

Smaller than  $\pm 0.01\%$  range/radiation

### Frequency interference influence All the model

Smaller than  $\pm 0.1\%$  range,  $20\text{ to }1000\text{MHz}$ , field strength up to  $30\text{ voltage/meter}$

### Resistant to transient voltage protection (option code T1)

#### All the model

$6\text{kV}$  peak value ( $0.5\ \mu\text{s}\text{--}100\text{kHz}$ )

$3\text{kV}$  peak value ( $8\times 20\text{ms}$ )

$6\text{kV}$  peak value ( $12\times 50\text{ms}$ );  $5\text{kV}$  peak value,  $1.25\text{MHz}$  waveshape

### Comprehensive performance index

Response time:  $<1\text{ nanosecond}$

Surge peak current:  $5,000\text{ ampere}$ , to the shell

Transient peak voltage:  $100\text{VDC}$

Circuit impedance:  $<25\ \Omega$

Note:

Check under  $68\text{--}0\text{F}$  ( $20^\circ\text{C}$ ) as per ASME Z210.1 (ANSI)

**量程与传感器的极限值**

**Limit Value of Range and Sensor**

表1. 3051CD, 3051CG, 3051L, 3051H型的量程与传感器极限值

Table 1 Limit value of range and sensor of 3051CD, 3051CG, 3051L and 3051H

量程 Range	最小量程 Min. Range	量程与传感器极限值 Limit Value of Range and Sensor						
		量程上限 (URL) Upper range limit (URL)	量程下限 (URL) Limit Value of Range and Sensor					
			3051CD差压 Differential pressure	3051CG表压 Gauge pressure	3051L差压 Differential pressure	3051L表压 Gauge pressure	3051H差压 Differential pressure	3051H表压 Gauge pressure
2	10mmH <sub>2</sub> O (100Pa)	150mmH <sub>2</sub> O (1500Pa)	-150mmH <sub>2</sub> O (-1500Pa)	-150mmH <sub>2</sub> O (-1500Pa)	NA	NA	NA	NA
3	12mmH <sub>2</sub> O (0.12kPa)	750mmH <sub>2</sub> O (7.5kPa)	-750mmH <sub>2</sub> O (-7.5kPa)	-750mmH <sub>2</sub> O (-7.5kPa)	-750mmH <sub>2</sub> O (-7.5kPa)	-750mmH <sub>2</sub> O (-7.5kPa)	-750mmH <sub>2</sub> O (-7.5kPa)	-750mmH <sub>2</sub> O (-7.5kPa)
4	40mmH <sub>2</sub> O (0.4kPa)	4mH <sub>2</sub> O (40kPa)	-4mH <sub>2</sub> O (-40kPa)	-4mH <sub>2</sub> O (-40kPa)	-4mH <sub>2</sub> O (-40kPa)	-4mH <sub>2</sub> O (-40kPa)	-4mH <sub>2</sub> O (-40kPa)	-4mH <sub>2</sub> O (-40kPa)
5	200mmH <sub>2</sub> O (2.0kPa)	20mH <sub>2</sub> O (200kPa)	-20mH <sub>2</sub> O (-200kPa)	-10mH <sub>2</sub> O (-100kPa)	-20mH <sub>2</sub> O (-200kPa)	-20mH <sub>2</sub> O (-100kPa)	-20mH <sub>2</sub> O (-200kPa)	-10mH <sub>2</sub> O (-100kPa)
6	700mmH <sub>2</sub> O (7.0kPa)	70mH <sub>2</sub> O (700kPa)	-70mH <sub>2</sub> O (-700kPa)	-10mH <sub>2</sub> O (-100kPa)	-70mH <sub>2</sub> O (-70kPa)	-70mH <sub>2</sub> O (-100kPa)	-70mH <sub>2</sub> O (-700kPa)	-10mH <sub>2</sub> O (-100kPa)
7	2.1mmH <sub>2</sub> O (21kPa)	210mH <sub>2</sub> O (2.1MPa)	-210mH <sub>2</sub> O (-2.1MPa)	-10mH <sub>2</sub> O (-100kPa)	-210mH <sub>2</sub> O (-2.1MPa)	-210mH <sub>2</sub> O (-100MPa)	-210mH <sub>2</sub> O (-2.1MPa)	-10mH <sub>2</sub> O (-100kPa)
8	7.0mH <sub>2</sub> O (70kPa)	700mmH <sub>2</sub> O (7MPa)	-700mH <sub>2</sub> O (-7MPa)	-10mH <sub>2</sub> O (-100kPa)	NA	NA	-70mH <sub>2</sub> O (-7kPa)	-10mH <sub>2</sub> O (-100kPa)
9	12mmH <sub>2</sub> O (120kPa)	2100mH <sub>2</sub> O (21MPa)	-2100mH <sub>2</sub> O (-21MPa)	-10mH <sub>2</sub> O (-100kPa)	NA	NA	-210mH <sub>2</sub> O (-2.1MPa)	-10mH <sub>2</sub> O (-100kPa)

表2. 3051T型量程与传感器极限值

Table 2 Limit value of 3051T range and sensor

量程 Range	最小量程 Min. Range	量程与传感器极限值 Limit Value of Range and Sensor		
		量程上限 Upper range limit	量程下限绝对压 Lower range limit Absolute pressure	量程下限表压 Lower range limit Gauge pressure
3	12mmH <sub>2</sub> O (0.12kPa)	750mmH <sub>2</sub> O (7.5kPa)	0mmH <sub>2</sub> O (0kPa)	-750mmH <sub>2</sub> O (-7.5kPa)
4	40mmH <sub>2</sub> O (0.4kPa)	4mH <sub>2</sub> O (40kPa)	0mmH <sub>2</sub> O (0kPa)	-4mH <sub>2</sub> O (-40kPa)
5	200mmH <sub>2</sub> O (2.00kPa)	20mH <sub>2</sub> O (200kPa)	0mmH <sub>2</sub> O (0kPa)	-10mH <sub>2</sub> O (-100kPa)
6	700mmH <sub>2</sub> O (7kPa)	70mH <sub>2</sub> O (700kPa)	0mmH <sub>2</sub> O (0kPa)	-10mH <sub>2</sub> O (-100kPa)
7	2.1mH <sub>2</sub> O (21kPa)	210mH <sub>2</sub> O (2.1MPa)	0mmH <sub>2</sub> O (0kPa)	-10mH <sub>2</sub> O (-100kPa)
8	10mH <sub>2</sub> O (100kPa)	1000mH <sub>2</sub> O (10MPa)	0mmH <sub>2</sub> O (0kPa)	-10mH <sub>2</sub> O (-100kPa)
9	40mH <sub>2</sub> O (400kPa)	4000mH <sub>2</sub> O (40MPa)	0mmH <sub>2</sub> O (0kPa)	-10mH <sub>2</sub> O (-100kPa)
10	120mH <sub>2</sub> O (1.2MPa)	12kmH <sub>2</sub> O (120MPa)	0mmH <sub>2</sub> O (0kPa)	-10mH <sub>2</sub> O (-100kPa)

设大气压为14ppsi

Set the barometric pressure to be 14ppsi

联系人: 姚经理: 13685509377 Email: 115192082@qq.com

### 零点与量程调整要求

零点与量程值可在表1-表3中所标明的量程极限内任意设定。  
量程必须大于或等于表1-表3中所标明的最小量程

### 应用场合

液体，气体与蒸汽的测量场合  
4-20mA(输出代码A)

### 输出

二线4-20mA，用户可选线性或平方根输出。数字过程变量叠加于4-20mA信号上，适用于任何使用HART协议的主机。

### 电源

需要外部电源。标准变送器(4-20mA)空载时工作在回路负载极限。最大回路电阻由外部电源供电电压决定，关系如下：  
最大回路电阻=41.5(电源电压-10.5)

### Adjustment requirements for zero point and range

The zero point and range value can be set arbitrarily within the range limit indicated in table 1-table 3.  
The range must be larger than or equal to the minimum range indicated in table 1-table 3.

### Application occasions

Application When liquid, gas and steam is measured  
4-20mA (output code A)

### Output

Two wire 4-20mA, the user can select linear or square root output. The digital process variable is superposed on the signal of 4-20mA, applicable to the host using HART protocol.

### Power supply

External power supply is required. Standard transmitter (4-20mA) works at 10.5-55Vdc during no load condition.

Circuit load limit The maximum circuit resistance is determined by the voltage of external power supply with the relationship as follows:

Maximum circuit resistance =41.5 (power supply voltage-10.5)

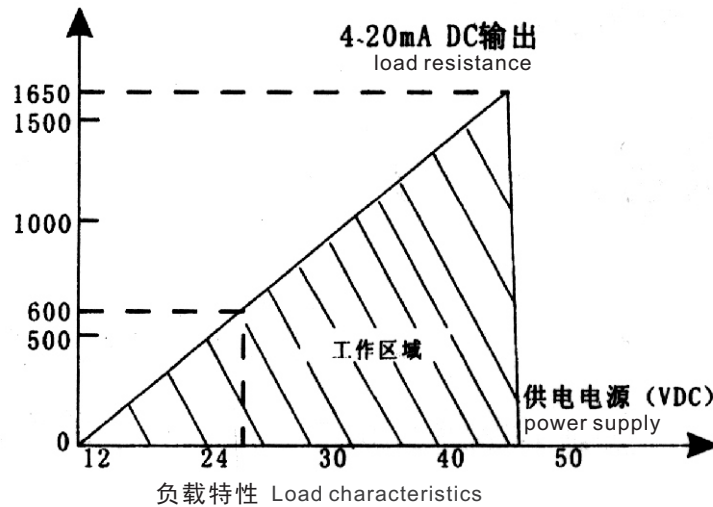

### 指示

可选数字液晶表头。

### 过压极限

变送器可承受以下极限压力而不致损坏

### 3051CD/CG型

量程2-6: 0.6MPa  
量程7: 2.1MPa  
量程8: 6MPa  
量程9: 20MPa

### 3051CA型

量程2-6: 0.6MPa  
量程7: 2.1MPa  
量程8: 6MPa  
量程9: 20MPa

### 3051TG/TA型

量程3-6: 3.5MPa  
量程7: 10MPa  
量程8: 13.8MPa  
量程9: 60MPa  
量程10: 150MPa

对于3051L型或选项代码为FA, FB, FC与FD的液位法兰，极限值为0kPa至法兰额定值或传感器额定压力值中的小者。

### Indication

Optional digital liquid crystal meter.

### Over-voltage limit

The transmitter is able to withstand the following limit pressure while not being damaged

### 3051CD/CG type

Range 2-6: 3.5MPa  
Range 7: 13.8MPa  
Range 8: 40MPa  
Range 9: 100MPa

### 3051CA type

Range 2-6: 3.5MPa  
Range 7: 13.8MPa  
Range 8: 40MPa  
Range 9: 100MPa

### 3051TG/TA type

Range 3-6: 3.5MPa  
Range 7: 10MPa  
Range 8: 13.8MPa  
Range 9: 60MPa  
Range 10: 150MPa

As for 3051L type or liquid flange with the option code of FA, FB, FC and FD, the limit value is 0kPa to the rated value of the flange or the rated pressure value of the sensor, whichever is the smaller.



表3. 3051L 型与液位法兰额定压力极限

Table 3. Rated pressure limit of 3051L type and liquid level flange

标准 Standard	类型 Type	碳钢额定值 Standard	不锈钢额定值 Rated vale of stainless steel
ANSI/ASME	Class150	285psig	275psig
ANSI/ASME	Class300	740psig	720psig
ANSI/ASME	Class600	1480psig	1440psig
100° F (38°C)下，额定值随温度升高而降低。 Under 100°F(38°C), the rated value decreases with the increase of temperature.			
DIN	pn10-40	40bar	40bar
DIN	pn10/60	16bar	16bar
DIN	pn25/40	40bar	40bar
100° F (38°C)下，额定值随温度升高而降低。 Under 100°F(38°C), the rated value decreases with the increase of temperature.			

**静压极限**

仅限3051CD型  
在3.45kPa至24.8MPa (选项 P9为31.0MPa)的静压下，工作在指标范围内。  
量程3: 3.45kPa至5.1MPa  
量程4: 3.45kPa至13.7MPa

**冲击压力极限**

3051T型冲击压力为：  
量程3-6: 13MPa  
量程7-10: 175MPa

**温度极限**

**环境**

-40至85°C  
带一体化表头: -20至80°C

**贮存**

-46至110°C  
带一体化表头: -40至85°C

**过程**

大于等于大气压下，见表4。

**Static pressure limit**

Only for 3051CD type  
Under the static pressure of 3.45kPa to 24.8MPa (option P9 is 31.0MPa), working within the index range.  
Range 3: 3.45kPa to 5.1MPa  
Range 4: 3.45kPa to 13.7MPa

**Impact pressure limit**

3051T type impact pressure is:  
Range 3-6: 13MPa  
Range 7-10: 175MPa

**Temperature limit**

**Environment**

-40 to 85°C  
With integrated meter: -20 to 80°C

**Storage**

-46 to 110°C  
With integrated meter: -40 to 85°C

**Process**

Larger than or equal to the barometric pressure, see Table 4.

联系人: 姚经理: 13685509377 Email: 115192082@qq.com

表4. 3051型过程温度极限

Table 4. 3051 type process temperature limit

3051CD,3051CG,3051CA	
充硅油传感器 Sensor filled with silicon oil	-40至121°C <sup>(2)</sup>
配传统法兰 With traditional flange	-40至149°C <sup>(2)</sup>
配液位法兰 With level flange	-40至149°C <sup>(2)</sup>
一体化阀组 Integrated valve block	
充惰性液传感器 sensor filled with inertial liquid	-18至85°C <sup>(3) (4)</sup>
3051H型(过程充液h li) 3051H type (process filled witquid )	
D.C硅油200 <sup>(1)</sup> D.C silicon oil 200 <sup>(1)</sup>	-40至191°C
惰性液 Inertial liquid	-45至177°C <sup>(4)</sup>
Neobee M-20 <sup>(1)</sup>	-18至191°C
3051T型(过程充液h li) 3051T type (process filled witquid )	
充硅油传感器 Sensor filled with silicon oil	-40至121°C <sup>(2)</sup>
充惰性液传感器 Sensor filled with inertia liquid	-30至121°C <sup>(2)</sup>
3051 L型低压侧温度极限 3051 L type temperature limit at the low pressure side	
充硅油传感器 Sensor filled with silicon oil	-40至121°C <sup>(2)</sup>
充惰性液传感器 Sensor filled with inertia liquid	-85至85°C
3051 L型高压侧温度极限(过程充液) 3051 L type temperature limit at the high pressure side (process filled with liquid)	
SylthermXLT Syltherm硅油704 <sup>(5)</sup> Syltherm silicon oil 704 <sup>(5)</sup> D. C. 硅油200 D.C. Silicon oil 200	-100至300° F (-73至149°C) 60至572° F (15至300°C) -40至400° F (-40至205°C)
惰性液 Inertial liquid	-50至350° F (-45至177°C)

(1) 过程温度超过1850F(85°C), 要求环境温度极限降低超出值的1/1.5(3051H型降低1/0.6)。

(2) 真空环境下极限为220°F(104°C), 压力低于3.4kPa时极限为1300F(54°C)。

(3) 真空环境下极限为1600F(71°C)。

(4) 不适用于3051CA型。

(5) 温度上限适用于使用毛细管, 远离变送器安装的远传密封装置。

(1) process temperature exceeds 1850F(85°C), it is required that the ambient temperature limit decrease exceeds 1/1.5 of the value (3051H type reduces by 1/0.6)

(2) the limit under vacuum environment is 2200F(104°C), the limit is 1300F(54°C) when the pressure is lower than 3.4kPa.

(3) The limit under vacuum environment is 1600F(71°C).

(4) Not applicable to 3051CA type.

(5) The upper limit of the temperature is applicable to the capillary, away from the remote transmitting sealing device installed on the transmitter

#### 容积变化量

小于0.005in<sup>3</sup>(0.08cm<sup>3</sup>)

#### 阻尼

模拟输出对阶跃输入变化的响应时间是由用户选择的一个时间常数(0-36秒)。该软件设定阻尼值不包括传感膜头的响应时间。

#### 机械性能指标 电气接口

1/2-14NPT, PG13.5, G1/2与M20 x 1.5(CM20)导线管。HART接口固定于端子块上。

#### Volume variation

Smaller than 0.005in<sup>3</sup>(0.08cm<sup>3</sup>)

#### Damp

The response time of analog output to the step input change is one time constant selected by the customer (0-36 seconds). The set damping value of this software does not include the response time of the sensing film head.

#### Mechanical performance index Electric interface

1/2-14NPT, PG13.5, G1/2 and M20 x 1.5(CM20) wire conduit. The HART interface is fixed on the terminal block.

### 过程接口

所有型号(除3051L与3051T)  
1/4-18NPT, 中心距为2 1/8英寸。  
1/2-14NPT, 中心距为2, 2 1/8或2 1/4英寸。

### 3051L型

高压侧: 2-, 3-或4-英寸, ANSI 150、300或600级  
法兰; 50、80或100毫米, PN40或10/16法兰。

低压侧: 法兰上, 1/4-18NPT  
接头上, 1/2-14NPT

### 3051L型

1/4-18NPT、1/2-14NPT阴螺纹, G1/2A  
DIN16288阳螺纹(仅限不锈钢, 量程3-7变送器),  
或压力反应罐F-250-C型(减压9/16-18压盖螺纹;  
1/4OD高压60°锥型管; 仅限不锈钢, 量程7变  
送器)。

### 过程接液件

#### 过程隔离膜片

隔离膜片材料 Isolation diaphragm material	3051CD/CG	3051T	3051CA	3051H	3051L
316L不锈钢 316L stainless steel	●	●	●	●	见后 See later
哈氏金C-276 Hastelloy C-276	●	●	●	●	
蒙乃尔 Monel	●		●		
钽 Tantalum	●			●	

### 排液/排气阀

316不锈钢, 哈氏合金C或蒙乃尔材料

### 过程法兰与接头

电镀碳钢, 316不锈钢, 哈氏合金C或蒙乃尔。

### 接液O型环

氟橡胶(或聚四氟乙烯)

### 3051L型过程接液件

#### 法兰式过程接口(变送器高压侧)

#### 过程膜片, 包括过程垫圈接触表面

316L不锈钢, 哈氏合金C-276或钽

#### 伸出部分

316L不锈钢, 或哈氏合金C。适用Schedule 40与  
80管。

#### 安装法兰

碳钢镀锌或不锈钢

#### 参考侧过程连接(变送器低压侧)

#### 隔离膜片

316L不锈钢或哈氏合金C-276

#### 参考侧法兰与接头

316L不锈钢  
非接液件

#### 电子外壳

低铜铝或316L不锈钢, NEMA4X, IP65, IP66

#### 涂层(仅限铝外壳)

聚氨酯

#### 表盖O型环

丁腈橡胶

### Process interface

All the model (except 3051L and 3051T)  
1/4-18NPT, the center distance is 2 1/8 inch.  
1/2-14NPT, the center distance is 2, 2 1/8 or 2 1/4 inch.

### 3051L type

High pressure side: 2-, 3- or 4- inch, ANSI 150, 300 or  
600 class flange; 50, 80 or 100 millimeters, PN40 or  
10/16 flange.

Low pressure side: on the flange, 1/4-18NPT  
On the joint, 1/2-14NPT

### 3051L type

1/4-18NPT, 1/2-14NPT female thread, G1/2A DIN16288  
male thread (only for stainless steel, range 3-  
7 transmitter), or pressure reaction tank F-250-C type  
(pressure relief 9/16-18 gland thread; 1/4OD high  
pressure 60° conical tube; only for stainless steel, range  
7 transmitter)

### Process liquid connection part

#### Process isolation diaphragm

### Liquid/gas drain valve

316 stainless steel, hastelloy C or Monel material

### Process flange and joint

Galvanized carbon steel, 316 stainless steel, hastelloy  
C or Monel.

### Liquid connection O-ring

Fluorine rubber (teflon)

### 3051L process liquid connection part

#### Flange process interface (high pressure side of the transmitter)

#### Process diaphragm, including process washer contact surface

316L stainless steel, hastelloy C-276 or tantalum

#### Protruding part

316L stainless steel, or hastelloy C. Applicable to tube  
Schedule 40 and 80.

#### Installation flange

Carbon steel galvanized or stainless steel

#### Reference side process connection (low pressure side of the transmitter)

#### Isolation diaphragm

316L stainless steel or hastelloy C-276

#### Reference side flange and joint

316L stainless steel

Non liquid connection part

#### Electronic external shell

Low copper-aluminum or 316L stainless steel, NEMA4X,  
IP65, Ip66

#### Electronic external shell

PU

#### Meter cover O-ring

Nitrile-butadiene rubber



## 3051C型压力变送器部件分解图与尺寸图 Exploded View and Dimensions of 3015 Type Pressure Transmitter

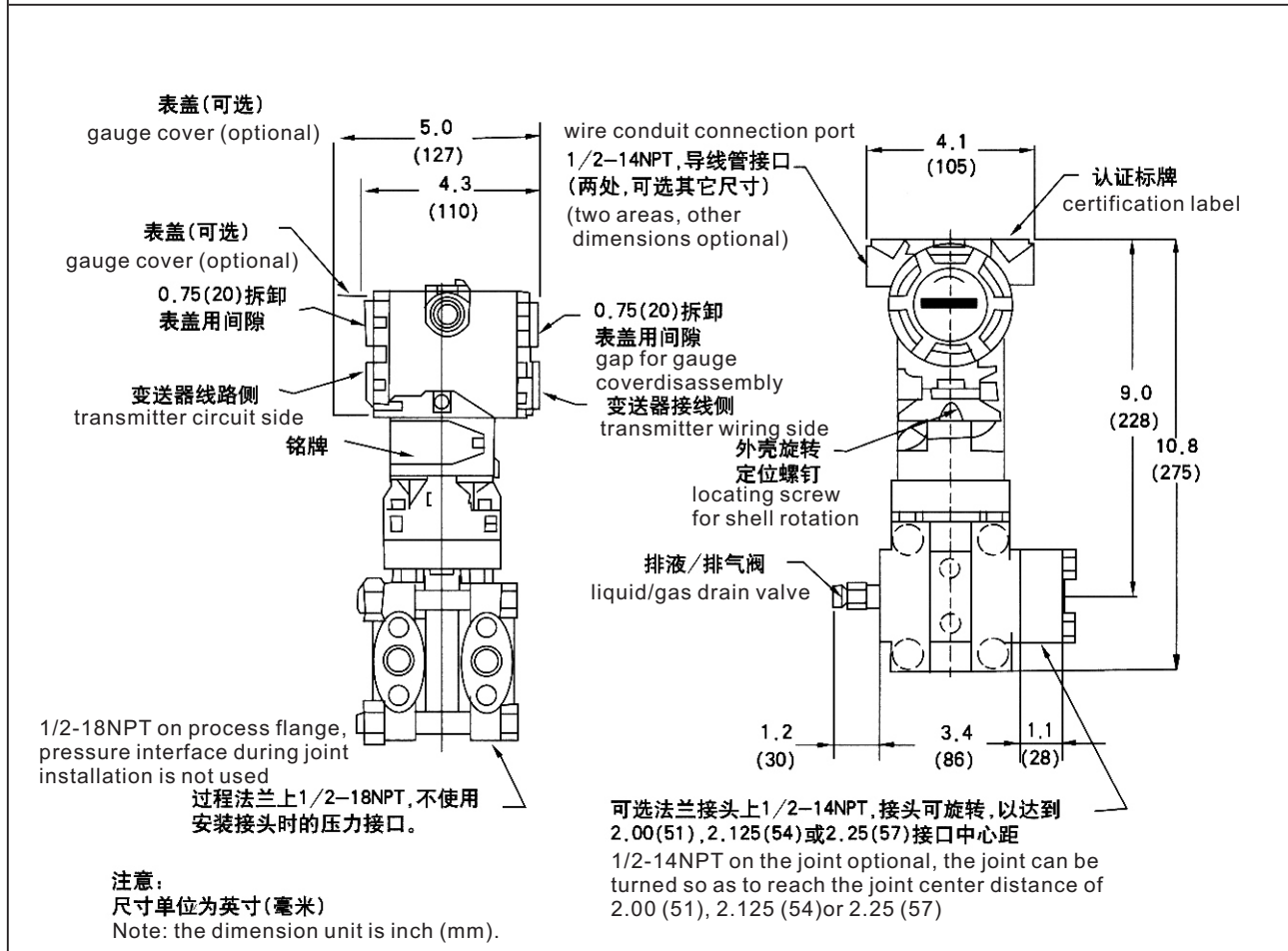
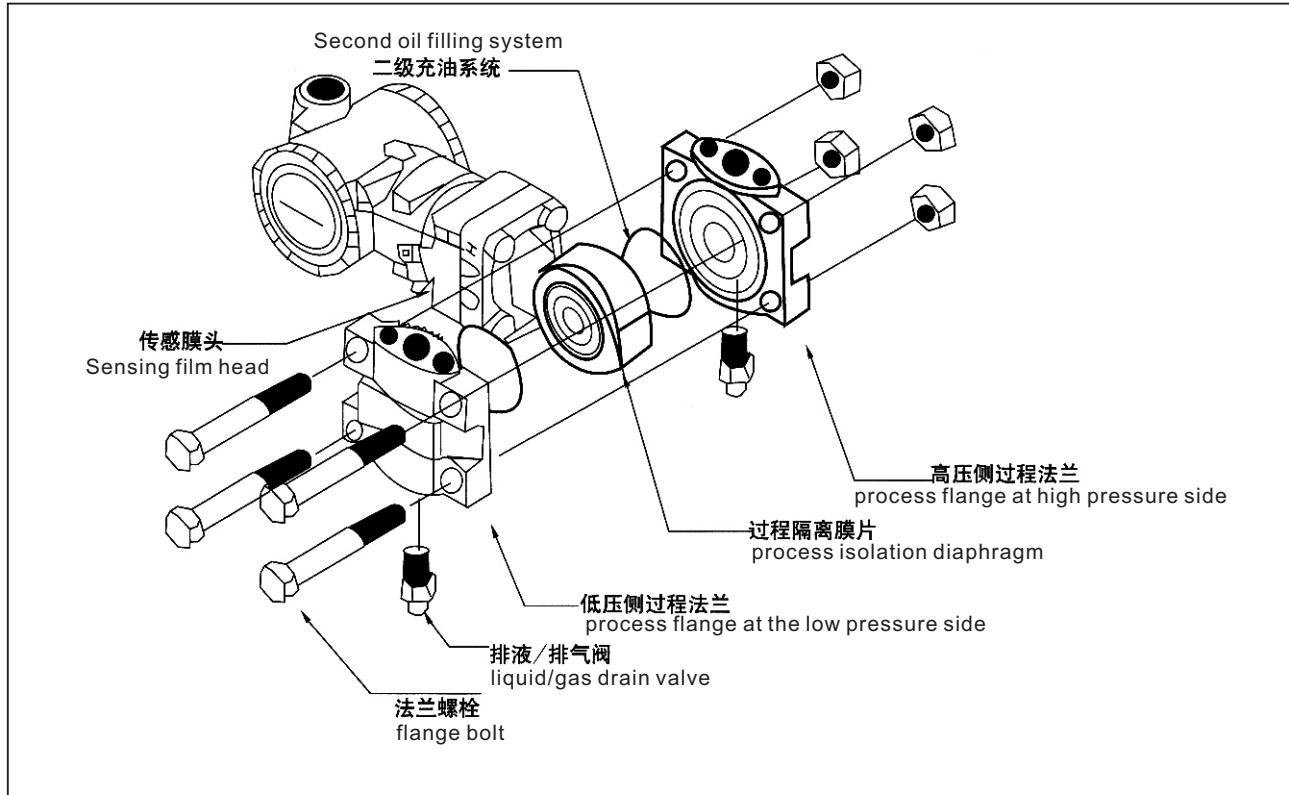

**3051C型安装支架，用于2英寸管道安装和面板的安装**  
**3051C Type Installation Frame, for 2 Inch Pipeline Installation and Panel Installation**

管道安装结构图

Structure diagram of pipeline installatio

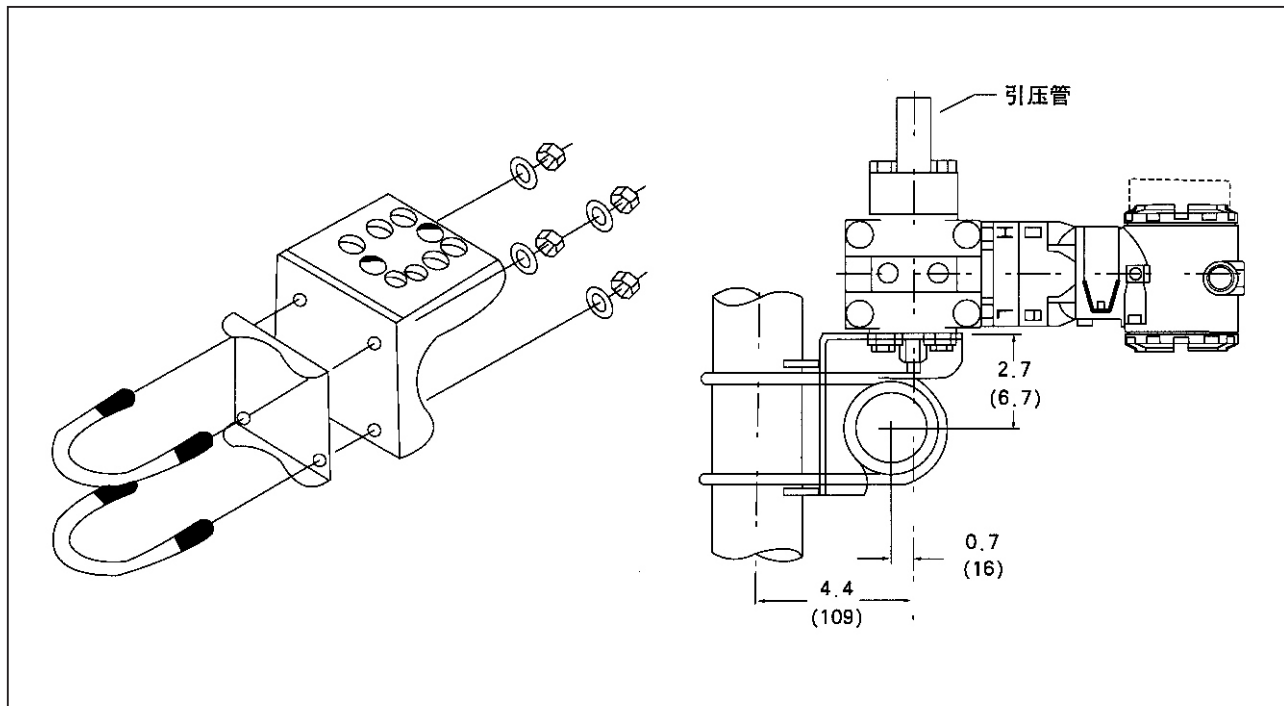

面板安装结构图提供 (7/16) -20× (3/4) 螺栓用于支架与变送器相连

Diagram of Panel installation structure (7/16) -20× (3/4) bolt is provided for connection

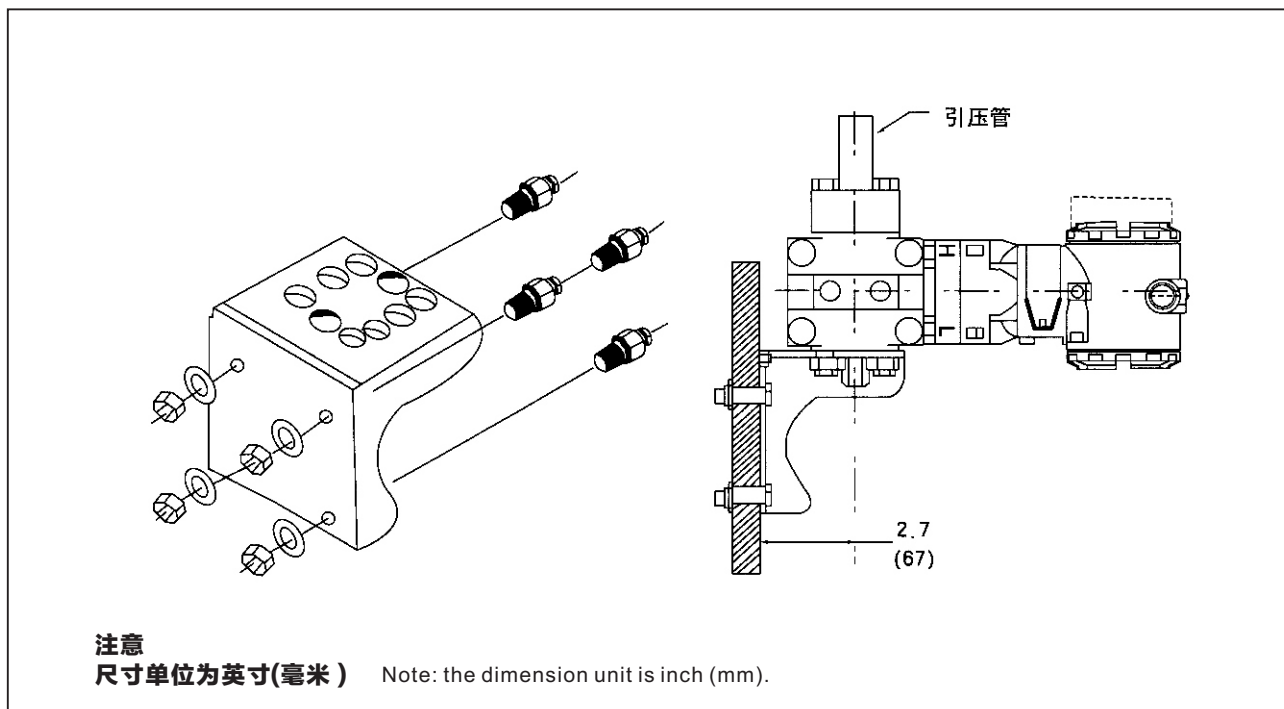

联系人：姚经理：13685509377    Email: 115192082@qq.com

**3051T型典型安装结构, 带有可选安装支架**  
**3051T typical installation structure, with optional installation frame**

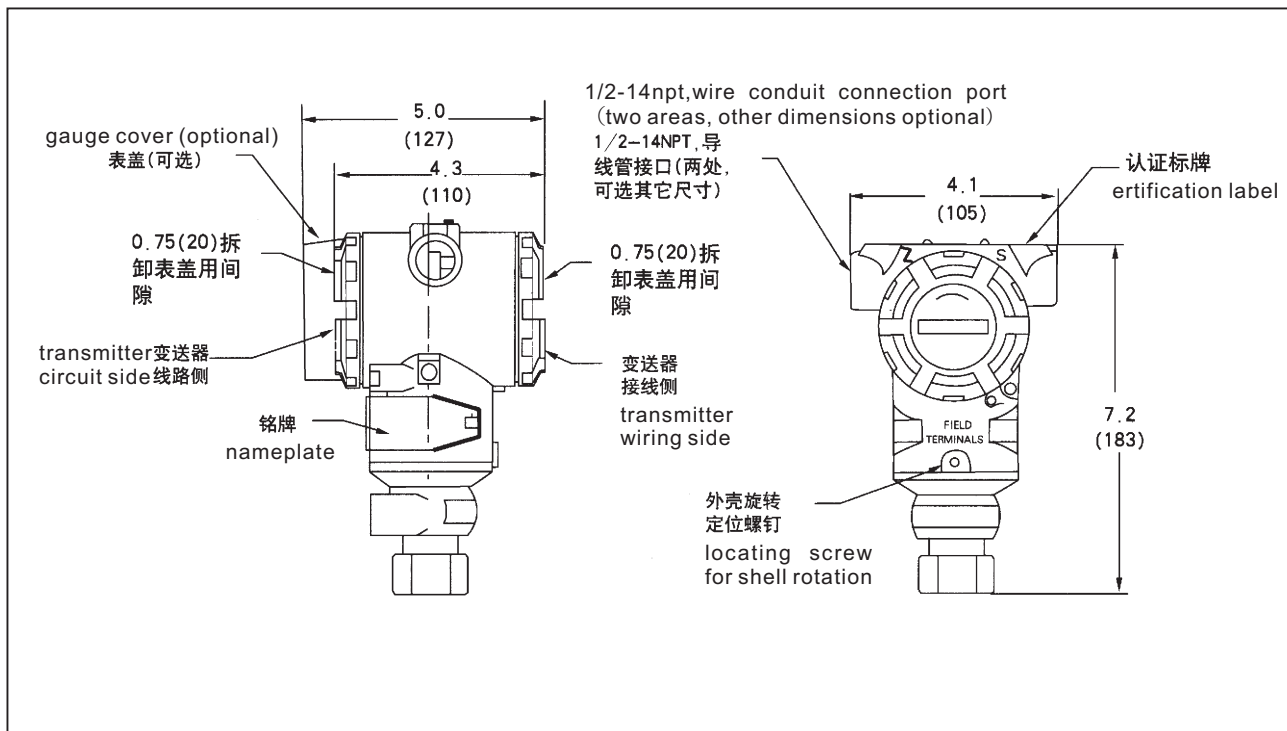

**3051T型尺寸图**  
**3051T Dimensions**

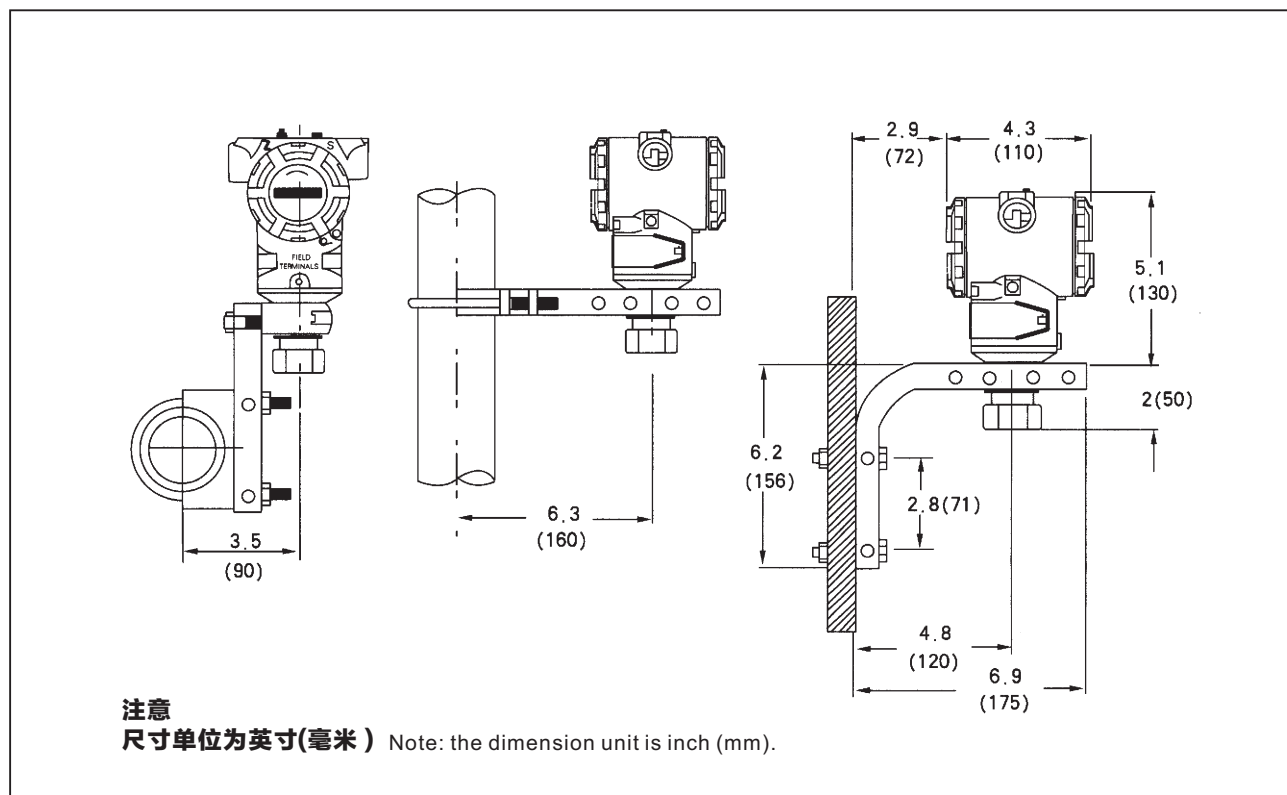

联系人: 姚经理: 13685509377 Email: 115192082@qq.com



## 3051T型典型安装结构, 带有可选安装支架 3051T typical installation structure, with optional installation frame

TK3051A/B型差压、表压、绝压变送器选型 TK3051A/B differential pressure, gauge pressure, absolute pressure						
型号 model	变送器类型 (选其一) transmitter type (select one)			CD	CG	CA
TK3051A-CD	高精度差压变送器 High-precision differential pressure transmitter			±0.05~0.075%FS		
TK3051A-CH	高精度表压变送器 High-precision gauge pressure transmitter			±0.05~0.075%FS		
TK3051A-CA	高精度绝压变送器 High-precision absolute pressure transmitter			±0.05~0.075%FS		
TK3051B-CD	差压变送器 differential pressure transmitter			±0.1~0.2%FS		
TK3051B-CH	表压变送器 gauge pressure transmitter			±0.1~0.2%FS		
TK3051B-CA	绝压变送器 absolute pressure transmitter			±0.1~0.2%FS		
代码 code	压力范围 (量程/最小量程) pressure range (range/minimum range)					
	3051CD型 3051CDtype	3051CG型 3051CGtype	3051CA型 3051CAtype			
2	-150至150mmH <sub>2</sub> O/10mmH <sub>2</sub> O (-1500至1500Pa/100Pa)	不提供 not	不提供 not			
3	-750至750mmH <sub>2</sub> O/12mmH <sub>2</sub> O (-7500至7500Pa/120Pa)	-750至750mmH <sub>2</sub> O/12mmH <sub>2</sub> O (-7500至7500Pa/120Pa)	-750至750mmH <sub>2</sub> O/12mmH <sub>2</sub> O (-7500至7500Pa/120Pa)			
4	-4.0至4.0mH <sub>2</sub> O/40mmH <sub>2</sub> O (-7500至7500Pa/120Pa)	-4.0至4.0mH <sub>2</sub> O/40mmH <sub>2</sub> O (-7500至7500Pa/120Pa)	-4.0至4.0mH <sub>2</sub> O/40mmH <sub>2</sub> O (-7500至7500Pa/120Pa)			
5	-20至20mH <sub>2</sub> O/0.2mH <sub>2</sub> O (-200至200kPa/2.0kPa)	-10至20mH <sub>2</sub> O/0.2mH <sub>2</sub> O (-100至200kPa/2.0kPa)	-10至20mH <sub>2</sub> O/0.2mH <sub>2</sub> O (-100至200kPa/2.0kPa)			
6	-70至70mH <sub>2</sub> O/0.7mH <sub>2</sub> O (-700至700kPa/7.0kPa)	-10至70mH <sub>2</sub> O/0.7mH <sub>2</sub> O (-100至700kPa/7.0kPa)	-10至70mH <sub>2</sub> O/0.7mH <sub>2</sub> O (-100至700kPa/7.0kPa)			
7	-210至210mH <sub>2</sub> O/2.1mH <sub>2</sub> O (-2.1至2.1MPa/21kPa)	-10至210mH <sub>2</sub> O/2.1mH <sub>2</sub> O (-0.1至2.1MPa/21kPa)	-10至210mH <sub>2</sub> O/2.1mH <sub>2</sub> O (-0.1至2.1MPa/21kPa)			
8	-700至700mH <sub>2</sub> O/7.0mH <sub>2</sub> O (-7.0至7.0MPa/70kPa)	-10至700mH <sub>2</sub> O/7.0mH <sub>2</sub> O (-0.1至7.0MPa/70kPa)	-10至700mH <sub>2</sub> O/7.0mH <sub>2</sub> O (-0.1至7.0MPa/70kPa)			
9	-2100至2100mH <sub>2</sub> O/21mH <sub>2</sub> O (-2.1至2.1MPa/210kPa)	-10至2100mH <sub>2</sub> O/21mH <sub>2</sub> O (-0.1至2.1MPa/210kPa)	-10至2100mH <sub>2</sub> O/21mH <sub>2</sub> O (-0.1至2.1MPa/210kPa)			
注: 3051CG型的量程下限随大气压的变化而改变 note: change with the change of barometric pressure under 3051 type						
代码 code	输出 output			CD	CG	CA
A	4-20mA, 带有基于HART协议的数字信号 4-20mA, with digital signal based on HART protocol					
B	PROF 1BUS-PA总线					
代码 code	结构材料 aterial of structural part			CD	CG	CA
	法兰材料 flange material	排液/排气阀 liquid/gas drain valve	法兰接头材料 flange joint material			
5	电镀碳钢 electroplated carbon steel	不锈钢 stainless	电镀碳钢 electroplated carbon steel			
2	不锈钢 stainless	不锈钢 stainless	不锈钢 stainless			
3	不锈钢 stainless	哈氏合金C hastelloyC	哈氏合金C hastelloyC			
8	电镀碳钢 oplated carbon steel	哈氏合金C hastelloyC	电镀碳钢 oplated carbon steel			
7	不锈钢 stainless	哈氏合金C hastelloyC	不锈钢 stainless			
代码 code	隔离膜片材料 Isolated membrane material			CD	CG	CA
2	316L不锈钢 316Lstainless					
3	哈氏合金C-276 hastelloyC-276					
4	蒙乃尔 Monel					
5	钽 (仅适用于3051CD与CG型, 量程4-9, 不适用于3051CA型) tantalum (only applicable to 3051CD and CG, range 4-9. Not applicable to 3051CA type)					
代码 code	O型环 O-ring			CD	CG	CA
A	氟橡胶 fluoride rubber					
B	聚四氟乙烯 PTFE					
代码 code	灌充液 filling liquid			CD	CG	CA
1	硅油 silicon oil					
2	惰性液 (卤代烃) inertia oil (halogenated hydrocarbon)					
代码 code	外壳材料 shell material	导线管入口尺寸 entry size of wire conduit		CD	CG	CA
B	铝, 覆聚氨酯涂层 aluminum, coated with PU coating	M20×1.5 (CM20)				

注意: 特殊选项请与销售代表联系。

Note: please contact the sales representative for special options.

## 续选型 Continuous option type

代码 model	阀组一体化安装选项 Valve integration installation option	CD	CG	CA
S5	一体化安装型阀组 Integrated installation valve block			
代码 Code	远传(可远) 注: 标准法兰和接头螺栓是 316不锈钢 Remote transmitting (remote possible) Note: standard flange and joint bolt are made from stainless steel	CD	CG	CA
S1	一个远传(直接安装式或毛细管式) One remote transmitting (directly installed or capillary type)	.	.	.
S2	两个远传(直接安装式或毛细管式) Two remote transmitting (directly installed or capillary type)	.	.	.
代码 Code	可选全焊接远传 (用于高真空场合) 注: 标准法兰和接头螺栓是不锈钢 Optional fully-welded remote transmitting (applicable to the high vacuum situation) Note: standard flange and joint bolt are made from stainless steel	CD	CG	CA
S7	一个远传, 全焊接系统(毛细管式) one remote transmitting, fully welded system (capillary type)	.	.	.
S8	两个远传, 全焊接系统(毛细管式) Two remote transmitting, fully welded system (capillary type)	.	.	.
S0	一个远传, 全焊接系统(直接安装式) One remote transmitting, fully welded system (directly installed type)	.	.	.
S9	两个远传, 全焊接系统(一个直接安装式, 一个毛细管式) Two remote transmitting, fully welded system (one directly installed type, one capillary type)	.	.	.
代码 Code	安装支架选项 Installation frame option	CD	CG	CA
B1	传统法兰支架, 用于2英寸管道安装, 碳钢螺栓 Traditional flange support, used for 2 inch pipeline installation, carbon steel bolt	.	.	.
B2	传统法兰支架, 用于面板安装, 碳钢螺栓 Traditional flange support, used for panel installation, carbon steel bolt	.	.	.
B3	传统法兰平支架, 用于2英寸管道安装, 碳钢螺栓 Traditional flange flat support, used for 2 inch pipeline installation, carbon steel bolt	.	.	.
B7	B1支架, 配不锈钢螺栓 B1 support, with stainless steel bolt	.	.	.
B8	B2支架, 配不锈钢螺栓 B1 support, with stainless steel bolt	.	.	.
B9	B3支架, 配不锈钢螺栓 B3 support, with stainless steel bolt	.	.	.
BA	不锈钢B1支架, 配不锈钢螺栓 Stainless steel B1 support, with stainless steel bolt	.	.	.
BC	不锈钢B3支架, 配不锈钢螺栓 Stainless steel B3 support, with stainless steel bolt	.	.	.
代码 Code	螺栓选项 Bolt option	CD	CG	CA
L4	316不锈钢螺栓 316 stainless bolt	.	.	.
L5	碳钢镀锌螺栓 Carbon steel galvanized bolt	.	.	.
代码 Code	表头可选 Meter optional	CD	CG	CA
M5	液晶表头, 用于铝制外壳 Liquid crystal meter, used for aluminum shell	.	.	.
代码 Code	其它选项 Other options	CD	CG	CA
Q4	校证书 Inspection certificate	.	.	.
Q16	卫生型远传膜片表面光洁认证 Surface finish certification for hygiene remote transmitting diaphragm	.	.	.
Q3	安全型仪表系统的质量认证 Quality certification of safe instrument system	.	.	.
J1	有本机零点或量程调整 zero point or range adjustment with native machine	.	.	.
J3	无本机零点或量程调整 zero point or range adjustment without native machine	.	.	.
T1	耐瞬变电压保护端子块 protection terminal block resistant to transient voltage	.	.	.
C1	定制软件组态 Customized software configuration	.	.	.
P1	静压测试 Static pressure test	.	.	.
P2	清洗, 用于特殊应用场合 Cleaning, for special application site	.	.	.
DF	1/2-14NPT过程接口(法兰按头)一材料与法兰材料相同 1/2-14NPT process interface (flange joint) - the material is the same as the flange material	.	.	.
p9	30.1MPa静压极限(仅限3051 CD型, 量程3-9) 30.1MPa static pressure limit (only for 3051 CD, range 3-9)	.	.	.
V5	外部接地螺钉组件 Screw assembly of external grounding	.	.	.
代码 Code	危险场所认证 Certification of dangerous site	CD	CG	CA
E5	本安 iII CT4/CT6 Intrinsic safety iII CT4/CT6	.	.	.
K5	隔爆 dII CT4/CT6 Explosion suppression dII CT4/CT6	.	.	.

## 3051L型液位变送器选型 3051L type liquid level transmitter selection

型号 Model	变送器类型 Transmitter Type			
3051L	法兰安装液位变送器 Flange installed liquid level transmitter			
代码 Code	压力范围 (量程 / 最小量程) Pressure scope (range/minimum range)			
3	-750至750mmH2O/12mmH2O (-7500至7500Pa/4kPa)			
4	-4至4.0mH2O/40mmH2O (-40至40kPa/6kPa)			
5	-20至20mH2O/0.2mH2O (-200至200kPa/20kPa)			
6	-70至70mH2O/0.7mH2O (-700至700kPa/70kPa)			
7	-210至210mH2O/2.1mH2O (-2.1至2.1MPa/21kPa)			
代码 Code	输出 Output			
A	4-20mA 带有基于 HART 协议的数字信号			
B	脉冲输出 The digital signal based on HART			
代码 Code	高压侧 High pressure side	材料 Material	伸出长度 Protruding length	
	隔膜片尺寸 Diaphragm			
G0	2英寸 / DN50	316L 不锈钢	只有平膜片式	
H0	2英寸 / DN50	哈氏合金	只有平膜片式	
J0	2英寸 / DN50	钽	只有平膜片式	
A0	3英寸 / DN80	316L 不锈钢	平膜片式	
A2	3英寸 / DN80	316L 不锈钢	2英寸 / 50mm	
A4	3英寸 / DN80	316L 不锈钢	4英寸 / 150mm	
A6	3英寸 / DN80	316L 不锈钢	6英寸 / 150mm	
B0	4英寸 / DN100	316L 不锈钢	平膜片式	
B2	4英寸 / DN100	316L 不锈钢	2英寸 / 50mm	
B4	4英寸 / DN100	316L 不锈钢	4英寸 / 100mm	
B6	4英寸 / DN100	316L 不锈钢	6英寸 / 150mm	
C0	3英寸 / DN80	哈氏合金	平膜片式	
C2	3英寸 / DN80	哈氏合金	2英寸 / 50mm	
C4	3英寸 / DN80	哈氏合金	4英寸 / 100mm	
C6	3英寸 / DN80	哈氏合金	6英寸 / 150mm	
D0	4英寸 / DN100	哈氏合金	平膜片式	
D2	4英寸 / DN100	哈氏合金	2英寸 / 50mm	
D4	4英寸 / DN100	哈氏合金	4英寸 / 100mm	
D6	4英寸 / DN100	哈氏合金	6英寸 / 150mm	
E0	3英寸 / DN80	钽	只有平膜片式	
F0	4英寸 / DN100	钽	只有平膜片式	
代码 Code	安装法兰 Installation flange	ANSI 或 DIN ANSI or DIN	材料 Material	伸出长度 Protruding length
	尺寸 Dimensions	法兰等级 Flange Class		
M	2英寸	150级	碳钢	2英寸 DN50
A	3英寸	150级	碳钢	3英寸 DN80
B	4英寸	150级	碳钢	4英寸 DN100
N	2英寸	300级	碳钢	2英寸 DN50
C	3英寸	300级	碳钢	3英寸 DN80
D	4英寸	300级	碳钢	4英寸 DN100
P	2英寸	600级	碳钢	2英寸 DN50
E	3英寸	600级	碳钢	3英寸 DN80
X	2英寸	150级	不锈钢	2英寸 DN50
F	3英寸	150级	不锈钢	3英寸 DN80
G	4英寸	150级	不锈钢	4英寸 DN100
Y	2英寸	300级	不锈钢	2英寸 DN50
H	3英寸	300级	不锈钢	3英寸 DN80
J	4英寸	300级	不锈钢	4英寸 DN100
Z	2英寸	600级	不锈钢	2英寸 DN50
L	3英寸	600级	不锈钢	3英寸 DN80
Q	DN50	PN10/16	碳钢	2英寸 DN50
R	DN80	PN40	碳钢	3英寸 DN80
S	DN100	PN40	碳钢	4英寸 DN100
V	DN100	PN10/16	碳钢	4英寸 DN100
K	DN50	PN10/40	不锈钢	2英寸 DN50
T	DN80	PN40	不锈钢	3英寸 DN80
U	DN100	PN40	不锈钢	4英寸 DN100
W	DN100	PN10/16	不锈钢	4英寸 DN100
代码 Code	过程充液 - 高压侧 Process Liquid Filling - High Pressure Side	温度极限 Temperature Limit		
A	Syltherm XLT	-100至300°F (-73至135°C)		
C	Syltherm 硅油 704 Syltherm silicon oil 704	60至572°F (15至300°C)		
D	D.C. 硅油 200 D.C. Silicon oil 200	-40至400°F (-40至205°C)		



## 续选型号 Continuous option type

代码 Code	低压侧结构 Structure at Low Pressure Side	法兰接头 Flange Joint	膜片材料 Diaphragm Material	传感器充液 Liquid Filling of Sensor		
11	表压 Gauge pressure	不锈钢 Stainless steel	316L SST	硅油 Silicon oil		
21	表压 Gauge pressure	不锈钢 Stainless steel	316L SST	硅油 Silicon oil		
22	表压 Gauge pressure	不锈钢 Stainless steel	哈氏合金C-275 Hastelloy C-275	硅油 Silicon oil		
23	表压 Gauge pressure	不锈钢 Stainless steel	316L SST	硅油 Silicon oil		
2A	表压 Gauge pressure	不锈钢 Stainless steel	钽 Tantalum	惰性液(卤代烃) Inertia liquid (halogenated hydrocarbon)		
2B	表压 Gauge pressure	不锈钢 Stainless steel	316L SST	惰性液(卤代烃) Inertia liquid (halogenated hydrocarbon)		
2C	表压 Gauge pressure	不锈钢 Stainless steel	哈氏合金C-275 Hastelloy C-275	惰性液(卤代烃) Inertia liquid (halogenated hydrocarbon)		
31	表压 Gauge pressure	不锈钢 Stainless steel	316L SST	硅油(要求选代码S1) Silicon oil (it is required to select the code S1)		
代码 Code	O型环材料 O-ring material					
A	氟橡胶 Florine rubber					
代码 Code	外壳材料 Material of external shell	导管入口尺寸 Entry size of the conduit				
B	铝, 覆聚脲涂层 Aluminum, covered with PU	M20X 1.5(CM20)				
代码 Code	远传(可选) Remote transmitting (optional)					
S1	一个远传(低压侧代码应为31, 采用毛细管式远传) One remote transmitting (the code at the low pressure side should be 31, with capillary type of remote transmitting)					
代码 Code	法兰与接头用螺栓(可选) Flange and joint bolts (optional)					
L5	碳钢镀锌螺栓 Carbon steel galvanized bolt					
代码 Code	表头(选项) Meter (optional)					
M5	液晶表头, 用于铝制外壳 Liquid crystal meter, for aluminum shell					
代码 Code	其它选项 Other options					
Q4	校验数据单 Check the data sheet					
Q8	材料可跟踪性证书 Material traceability certificate					
C1	定制软件组态 Customized software configuration					
CN	外部接地螺钉组件 External grounding bolt assembly					
V5	下套冲洗连接选项 Lower sleeve flushing connection option					
代码 Code	冲洗连接环材料 Flushing Connection Ring Material	冲洗连接 Flushing Connection		膜片尺寸 Diaphragm Size		
		数量 Qty.	尺寸 Size	2英寸 2-inch	3英寸 2-inch	4英寸 2-inch
F1	不锈钢 Stainless steel	1	1/4	●	●	●
F2	不锈钢 Stainless steel	2	1/4	●	●	●
F2 (1)	哈氏合金 Hastelloy	1	1/4	●	●	●
F4 (1)	哈氏合金 Hastelloy	2	1/4	●	●	●
F7	不锈钢 Stainless steel	1	1/4	●	●	●
F8	不锈钢 Stainless steel	2	1/4	●	●	●
F9	哈氏合金 Hastelloy	1	1/4	●	●	●
F0	哈氏合金 Hastelloy	2	1/4	●	●	●
(1)注: F3, F4不适用于选项代码A0, B0, G0。 (1) Note: F3 and F4 are not applicable to option code A0, BO, GO.						
典型型号: 3051L 2 A A0 A D 21 A A M5 Typical mode: 3051L 2 A A0 A D 21 A A M5						
代码 Code	危险场所认证 Dangerous site certification					
E5	本安 I a II CT4/CT6 Intrinsic safety I a II CT4/CT6					
K5	隔爆 d II CT4/CT6 Explosion suppression d II CT4/CT6					

## 高温高压变送器 High temperature and high pressure transmitter

代码 Code	低压侧结构 Structure at Low Pressure Side	法兰接头 Flange Joint	膜片材料 Diaphragm Material	传感器充液 Liquid Filling of Sensor		
11	表压 Gauge pressure	不锈钢 Stainless steel	316L SST	硅油 Silicon oil		
21	表压 Gauge pressure	不锈钢 Stainless steel	316L SST	硅油 Silicon oil		
22	表压 Gauge pressure	不锈钢 Stainless steel	哈氏合金C-275 Hastelloy C-275	硅油 Silicon oil		
23	表压 Gauge pressure	不锈钢 Stainless steel	316L SST	硅油 Silicon oil		
2A	表压 Gauge pressure	不锈钢 Stainless steel	钽 Tantalum	惰性液(卤代烃) Inertia liquid (halogenated hydrocarbon)		
2B	表压 Gauge pressure	不锈钢 Stainless steel	316L SST	惰性液(卤代烃) Inertia liquid (halogenated hydrocarbon)		
2C	表压 Gauge pressure	不锈钢 Stainless steel	哈氏合金C-275 Hastelloy C-275	惰性液(卤代烃) Inertia liquid (halogenated hydrocarbon)		
31	表压 Gauge pressure	不锈钢 Stainless steel	316L SST	硅油(要求选代码S1) Silicon oil (it is required to select the code S1)		
代码 Code	O型环材料 O-ring material					
A	氟橡胶 Florine rubber					
代码 Code	外壳材料 Material of external shell	导管入口尺寸 Entry size of the conduit				
B	铝, 覆聚氨基酯涂层 Aluminum, covered with PU	M20X 1.5(CM20)				
代码 Code	远传(可选) Remote transmitting (optional)					
S1	一个远传(低压侧代码应为31, 采用毛细管式远传) One remote transmitting (the code at the low pressure side should be 31, with capillary type of remote transmitting)					
代码 Code	法兰与接头用螺栓(可选) Flange and joint bolts (optional)					
L5	碳钢镀锌螺栓 Carbon steel galvanized bolt					
代码 Code	表头(选项) Meter (optional)					
M5	液晶表头, 用于铝制外壳 Liquid crystal meter, for aluminum shell					
代码 Code	其它选项 Other options					
Q4	校验数据单 Check the data sheet					
Q8	材料可跟踪性证书 Material traceability certificate					
C1	定制软件组态 Customized software configuration					
CN	外部接地螺钉组件 External grounding bolt assembly					
V5	下套冲洗连接选项 Lower sleeve flushing connection option					
代码 Code	冲洗连接环材料 Flushing Connection Ring Material	冲洗连接 Flushing Connection		膜片尺寸 Diaphragm Size		
		数量 Qty.	尺寸 Size	2英寸 2-inch	3英寸 2-inch	4英寸 2-inch
F1	不锈钢 Stainless steel	1	1/4	●	●	●
F2	不锈钢 Stainless steel	2	1/4	●	●	●
F2 (1)	哈氏合金 Hastelloy	1	1/4	●	●	●
F4 (1)	哈氏合金 Hastelloy	2	1/4	●	●	●
F7	不锈钢 Stainless steel	1	1/4	●	●	●
F8	不锈钢 Stainless steel	2	1/4	●	●	●
F9	哈氏合金 Hastelloy	1	1/4	●	●	●
F0	哈氏合金 Hastelloy	2	1/4	●	●	●
(1)注: F3, F4不适用于选项代码A0, B0, G0。 (1) Note: F3 and F4 are not applicable to option code A0, BO, GO.						
典型型号: 3051L 2 A A0 A D 21 A A M5 Typical mode: 3051L 2 A A0 A D 21 A A M5						
代码 Code	危险场所认证 Dangerous site certification					
E5	本安 ia II CT4/CT6 Intrinsic safety ia II CT4/CT6					
K5	隔爆 d II CT4/CT6 Explosion suppression d II CT4/CT6					

代码 Code	安装支架选项 Installation frame option		
B1	传统法兰支架, 用于2英寸管道安装, 碳钢螺栓 Traditional flange support, used for 2 inch pipeline installation, carbon steel bolt		
B2	传统法兰支架, 用于面板安装, 碳钢螺栓 Traditional flange frame, used for panel installation, carbon steel bolt		
B3	传统法兰支架, 用于面板安装, 碳钢螺栓 Traditional flange frame, used for panel installation, carbon steel bolt		
B7	B1支架, 配不锈钢螺栓 B1 support, with stainless steel bolt		
B8	B2支架, 配不锈钢螺栓 B2 support, with stainless steel bolt		
B9	B3支架, 配不锈钢螺栓 B3 support, with stainless steel bolt		
BA	不锈钢B1支架, 配不锈钢螺栓 Stainless B1 frame, with stainless steel bolt		
BC	不锈钢B3支架, 配不锈钢螺栓 Stainless B3 frame, with stainless steel bolt		
代码 Code	螺栓选项 Bolt option		
L4	316不锈钢螺栓 316 stainless steel bolt		
L5	碳钢镀锌螺栓 Carbon steel galvanized bolt		
代码 Code	Code 表头可选 Meter optional		
M5	液晶表头, 用于铝制外壳 Liquid crystal meter, for aluminum shell		
代码 Code	Code 其它选项 Other options		
Q4	校验证书 Check the certificate		
Q16	卫生型远传膜片表面光洁认证 Hygiene remote transmitting diaphragm surface finish certification		
Q3	安全型仪表系统的质量认证 Quality certification of safety instrument system		
J1	有本机零点或量程调整 Zero point or range adjustment with native machine		
J3	无本机零点或量程调整 Zero point or range adjustment without native machine		
T1	耐瞬变电压保护端子块 Protection terminal block resistant to transient voltage		
C1	定制软件组态 Customized software configuration		
P1	静压测试 Static pressure test		
P2	清洗, 用于特殊应用场合 Cleaning, used for special applications		
DF	1/2-14NPT过程接口(法兰接头) - 材料与法兰材料相同 1/2-14NPT process interface (flange joint) - material is the same as the flange material		
P9	31MPa静压极限 (仅限305 I CD型, 量程2-5) 31MPa static pressure limit (only for 305 I CD type, range 2-5)		
V5	外部接地螺钉组件 External grounding bolt assembly		
代码 Code	危险场所认证 Dangerous site certification		
E5	本安Intrinsic safety ia II CT4/CT6		
K5	隔爆Explosion suppression d II CT4/CT6		

联系人: 姚经理: 13685509377 Email: 115192082@qq.com

## RTW型螺纹安装远传法兰 RTW type bolt installation remote transmitting flange

型号 Model	法兰过程连接型式 Flange process connection type
1199RTW型 1199RTW type	螺纹安装远传法兰 Thread installation remote transmitting flange
代号 Code	清洗连接孔 Cleaning connection hole
11	无 None
21	有 Yes
代号 Code	远传装置膜片材料 Diaphragm material for remote transmitting device
A	316LSST
B	哈氏合金 C-276 Hastelloy C-276
C	钽 Tantalum
代号 Code	结构件材料 Material of structure part
11	上套为 316LSST, 安装环为碳钢 316LSST for upper sleeve Carbon steel for installation ring
代号 Code	下套材料 Material for lower sleeve
A	316LSST
B	哈氏合金 C-276 Hastelloy C-276
C	碳钢(电镀) Hastelloy C Carbon steel (electroplating)
代号 Code	引压连接孔 Pressure-leading connection hole
11	1/4" NPT(锥管螺纹) (conical pipe thread)
12	3/8" NPT(锥管螺纹) (conical pipe thread)
13	1/2" NPT(锥管螺纹) (conical pipe thread)
15	1" NPT(锥管螺纹) (conical pipe thread)
17	1-1/2" NPT(锥管螺纹) (不带清洗备用孔) (conical pipe thread) (without cleaning standby hole)
1199RTW	11 A 11 A 17 典型型号 Typical model

## PFW扁平式远传法兰 PFW flat remote transmitting flange

型号 Model	法兰过程连接型式 Flange process connection type
1199PFW型 1199pfw type	扁平式远传法兰 Flat type remote transmitting flange
代号 Code	型式 Type
11	标准 3" -150和300 lb Standard 3" -150 and 300 lb
代号 Code	远传装置膜片材料 Diaphragm material for remote transmitting device
A	316LSST
B	哈氏合金 C-276 Hastelloy C-276
C	钽 Tantalum
代号 Code	结构件材料 Material of structure part
11	上套为 316LSST, 安装环为碳钢 316LSST for upper sleeve Carbon steel for installation ring
代号 Code	壳体材料 Shell material
11	316LSST
1199PFW	11 A 11 A 17 典型型号 Typical model



# 1199 远传膜片密封件系统

## 1199 Remote Transmitting Diaphragm Sealing System

TK3051DP/TK3051GPTK3051T变送器带远传密封装置后，就成为TK3051DP/GP/T远传差压/压力变送器

TK3051DP/GP/T远传差压/压力变送器，可避免被测介质直接和变送器的隔离膜片接触的可靠测量方法，它适用于下面几种情况：

- 1、被测介质对变送器接头和敏感元件有腐蚀作用时；
- 2、需要将高温被测介质与变送器隔离时；
- 3、被测介质中有固体悬浮物或高粘度易堵塞变送器接头和压力容室时；
- 4、被测介质用引压管引出易固化或结晶时；
- 5、更换被测介质需要冲洗而不容交混时；
- 6、必须保持卫生条件，防止污染时。

TK3051DP/GP/T型带传密封装置的远传差压/压力变送器，仍具有TK3051DP/GP/T型差压/压力变送器的各种特点：

提供多种结构材料，远传装置组件焊接结构，可靠性强。充液腔低容积设计，减少温度影响，根据温度要求使用相应的灌充液。

When TK3051DP/TK3051GPTK3051T transmitter has remote sealing device, it becomes TK3051DP/GP/T remote differential pressure/pressure transmitter.

TK3051DP/GP/T remote transmitting differential pressure/pressure transmitter is a reliable measurement approach which can prevent the medium being measured from directly contacting the isolation diaphragm of the transmitter and it is applicable to the following conditions:

1. When the medium being measured is corrosive to the transmitter joint and sensitive elements;
2. When the high temperature medium being measured has to be isolated from the transmitter;
3. When there are solid suspended matters in the medium or when the medium is highly viscous which is easy to block the transmitter joint and pressure chamber;
4. When the leading-out medium with the pressure-leading tube is easy to solidify or crystallize.
5. When medium replacement requires flushing and it is not easy to mix.
6. When hygiene conditions must be kept to prevent the pollution.

TK3051DP/GP/T remote transmitting differential pressure/pressure transmitter with sealing device still has various characteristics of TK3051DP/GP/T differential pressure/pressure transmitter.

Various structure materials are provided. The assembly welding structure for remote transmitting device is highly reliable. The liquid filling chamber is designed with low volume to reduce the temperature influence. Relevant filling liquid shall be used depending on the temperature requirements.

### 1199RTW型螺纹安装式远传装置 (外形尺寸)

#### 1199RTW screw installation remote transmitting device (outline dimensions)

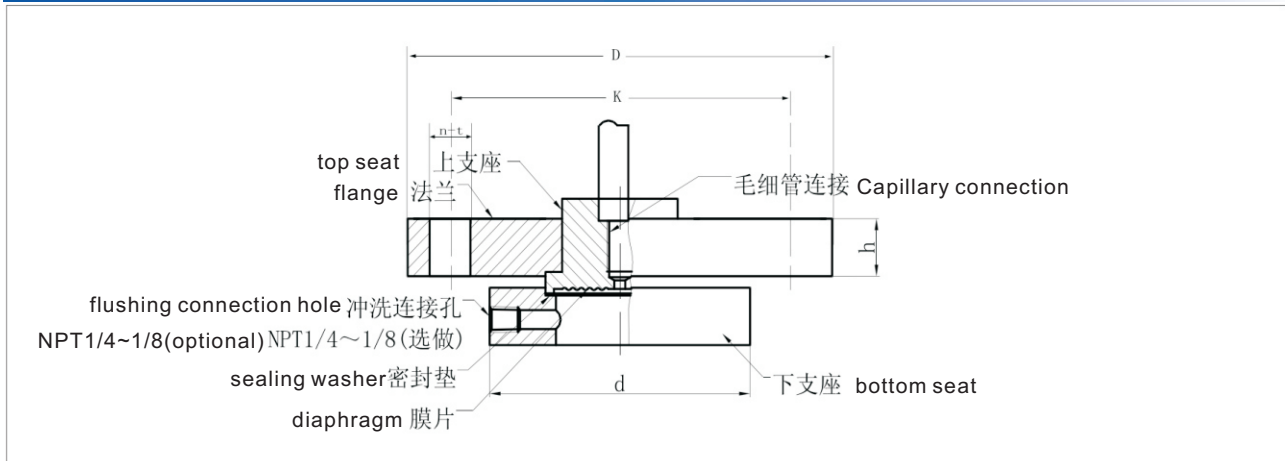

### 1199PFW型扁平式远传装置 (外形尺寸)

#### 1199PFW flat remote transmitting device (outline dimensions)

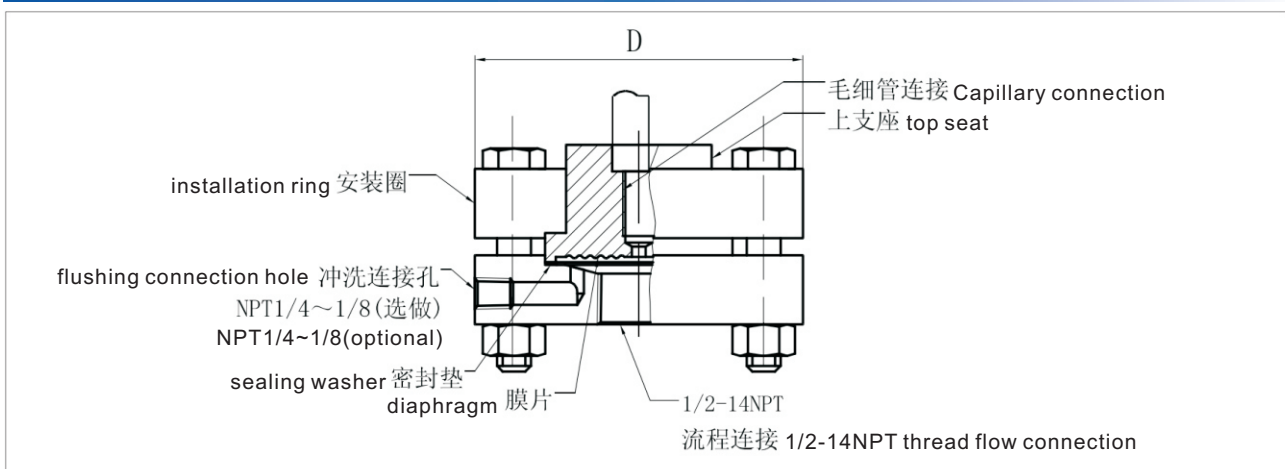

## 毛细管型号规格表 Capillary mode specification

11	名称 Name
199CAP型 199CAP type	毛细管 Capillary
代号 Code	毛细管材料和尺寸 Material and size of capillary
11	316SST, 内径为 c0.71mm 316SST, the inner diameter is c0.71mm
13	316SST, 内径为 c1.09mm 316SST, the inner diameter is c1.09mm
代号 Code	变送器端配件 Accessory parts at the transmitter end
D	1/2-20UNF-2A螺纹 1/2-20UNF-2A thread
代号 Code	结构件材料 Material for structure part
11	上套为 316SST, 安装环为碳钢 316SST for upper part, carbon steel for installation ring
代号 Code	毛细管长度 Length of capillary
5	1.5米 1.5m
10	3.0米 3.0m
15	4.5, 米 4.5m
20	6.0米 6.0m
25	7.5米 7.5m
30	10米 10m
代号 Code	远传法兰端配件 Accessory parts for remote transmitting flange end
A	1/2-20UNF-2A螺纹 1/2-20UNF-2A thread
C	1/2-20UNF-2A螺纹 1/2-20UNF-2A thread
代号 Code	保护套管 Protection sleeve
11	铠装 300SST 系列不锈钢 Armored 300SST series stainless steel
12	PVC 护套, 铠装 300SST 系列不锈钢 PVC jacket, armored 300SST series stainless steel
1199EFW	11 A 20 A11 典型型号 Typical model

## 远传法兰灌充液 Filling liquid for remote transmitting flange

代号 Code	远传法兰的灌充液 Filling liquid for remote transmitting flange
C10485-0007 01199-0032-0004 01199-0032-0012	DC-200 硅油 - 稳定范围 -40~+149°C (比重 0.934) DC-200 silicon oil - stability range -40~+149°C (specific weight 0.934) Slyatherm704 硅油 稳定范围 -15~+300°C (比重 0.934) Slyatherm704 silicon oil stability range -15~+300°C (specific weight 0.934) 丙油 稳定范围 -45~205°C (比重 1.85) 丙油 stability range -45~205°C (specific weight 1.85)
C10485-0007	— 典型型号
C10485-0007	— Typical model

注\*不能用于测量真空+测真空时温度极限应降低

Note: \* it can not be used to measure the vacuum + the temperature limit shall be lowered when the vacuum is measures

联系人: 姚经理: 13685509377 Email: 115192082@qq.com

## 法兰安装远传法兰 Flange installed remote transmitting flange

型号 Model	安装法兰类型Installed flange type	
1199FFW	法兰安装远传法兰Flange installation remote transmitting flange	
代号Code	冲洗备用孔Standby hole for flushing	
11	无None	
21	有Yes	
代号Code	远传装置膜片材料Diaphragm material for remote transmitting device	
A	316LSST	
B	哈氏合金C Hastelloy C-276	
C	钽 Tantalum	
D	蒙耐尔monel	
E	钛titanium	
代号Code	结构件材料Material of structure part	
11	上套为316SS, 法兰为碳钢 (电镀) Upper sleeve is 316SS, the flange is carbon steel (electroplating)	
代号Code	下套尺寸和材料Lower sleeve size and materia	
A21	150lb	316SS
B21	150lb	哈氏合金C Hastelloy C
E21	150lb	碳钢 Carbon steel
A41	150lb	316SS
B41	150lb	哈氏合金C Hastelloy C
E41	150lb	碳钢 Carbon steel
A51	150lb	316SS
B51	150lb	哈氏合金C Hastelloy C
E51	150lb	碳钢 Carbon steel
A71	150lb	316SS
B71	150lb	哈氏合金C Hastelloy C
E71	150lb	碳钢 Carbon steel
A22	300lb	316SS
B22	300lb	哈氏合金C Hastelloy C
E22	300lb	碳钢 Carbon steel
A42	300lb	316SS
B42	300lb	哈氏合金C Hastelloy C
E42	300lb	碳钢 Carbon steel
A52	300lb	316SS
B52	300lb	哈氏合金C Hastelloy C
E52	300lb	碳钢 Carbon steel
A72	300lb	316SS
B72	300lb	哈氏合金C Hastelloy C
E72	300lb	碳钢 Carbon steel
A24	600lb	316SS
B24	600lb	哈氏合金C Hastelloy C
E24	600lb	碳钢 Carbon steel
A44	600lb	316SS
B44	600lb	哈氏合金C Hastelloy C
E44	600lb	碳钢 Carbon steel
A54	600lb	316SS
B54	600lb	哈氏合金C Hastelloy C
E54	600lb	碳钢 Carbon steel
A74	600lb	316SS
1199FFW	11	A A21-典型型号

## RTW型螺纹安装远传法兰 RTW type bolt installation remote transmitting flange

型号 Model	法兰过程连接型式 Flange process connection type
1199RTW型 1199RTW type	螺纹安装远传法兰 Thread installation remote transmitting flange
代号 Code	清洗连接孔 Cleaning connection hole
11	无 None
21	有 Yes
代号 Code	远传装置膜片材料 Diaphragm material for remote transmitting device
A	316LSST
B	哈氏合金 C-276 Hastelloy C-276
C	钽 Tantalum
代号 Code	结构件材料 Material of structure part
11	上套为 316LSST, 安装环为碳钢 316LSST for upper sleeve Carbon steel for installation ring
代号 Code	下套材料 Material for lower sleeve
A	316LSST
B	哈氏合金 C-276 Hastelloy C-276
C	碳钢(电镀) Hastelloy C Carbon steel (electroplating)
代号 Code	引压连接孔 Pressure-leading connection hole
11	1/4" NPT(锥管螺纹) (conical pipe thread)
12	3/8" NPT(锥管螺纹) (conical pipe thread)
13	1/2" NPT(锥管螺纹) (conical pipe thread)
15	1" NPT(锥管螺纹) (conical pipe thread)
17	1-1/2" NPT(锥管螺纹) (不带清洗备用孔) (conical pipe thread) (without cleaning standby hole)
1199RTW	11 A 11 A 17 典型型号 Typical model

## PFW扁平式远传法兰 PFW flat remote transmitting flange

型号 Model	法兰过程连接型式 Flange process connection type
1199PFW型 1199pfw type	扁平式远传法兰 Flat type remote transmitting flange
代号 Code	型式 Type
11	标准 3" -150和300 lb Standard 3" -150 and 300 lb
代号 Code	远传装置膜片材料 Diaphragm material for remote transmitting device
A	316LSST
B	哈氏合金 C-276 Hastelloy C-276
C	钽 Tantalum
代号 Code	结构件材料 Material of structure part
11	上套为 316LSST, 安装环为碳钢 316LSST for upper sleeve Carbon steel for installation ring
代号 Code	壳体材料 Shell material
11	316LSST
1199PFW	11 A 11 A 17 典型型号 Typical model



## EFW型插入筒式远传法兰 EFW type inserted cylindrical remote transmitting flange

型号 Model	法兰过程连接型式 Flange process connection type
11199EFW型 11199EFW type	插入远传法兰 Inserted remote transmitting flange
代号 Code	插入筒直径和接液部材料 Insertion cylinder diameter and material of the liquid connection parts
11	3#316SST 不锈钢 Stainless steel
12	3#哈氏合金 C 不锈钢 Stainless steel
13	4#316SST 不锈钢 Stainless steel
14	4#哈氏合金 C 不锈钢 Stainless steel
代号 Code	远传装置膜片材料 Diaphragm material for remote transmitting device
A	316LSST
B	哈氏合金 C-276 Hastelloy C-276
C	钽 Tantalum
代号 Code	插入筒长度 Insertion cylinder length
20	50mm
40	100mm
60	150mm
代号 Code	法兰规格和材料 Flange specification and material
A11	50#有镀层碳钢, 最大工作压力 =1.97MPa, 在38°C时 50# with coated carbon steel, maximum working pressure=1.97MPa, At 38°C
A12	300#有镀层碳钢, 最大工作压力 =5.1MPa, 在38°C时 300# with coated carbon steel, maximum working pressure=5.1MPa, At 38°C
C13	600#有镀层碳钢, 最大工作压力 =9.9MPa, 在38°C时 600# with coated carbon steel, maximum working pressure=9.9MPa, At 38°C
1199EFW	11 A 20 A11 典型型号 Typical model

注:法兰规格、材料和工作压力, 如有特殊需求可另行定制;

Note: the flange specification, material and working pressure can be customized if you have special requirements

联系人: 姚经理: 13685509377 Email: 115192082@qq.com

**毛细管型号规格表**  
**Capillary mode specification**

11	名称 Name
199CAP型 199CAP type	毛细管 Capillary
代号 Code	毛细管材料和尺寸 Material and size of capillary
11	316SST, 内径为 c0.71mm 316SST, the inner diameter is c0.71mm
13	316SST, 内径为 c1.09mm 316SST, the inner diameter is c1.09mm
代号 Code	变送器端配件 Accessory parts at the transmitter end
D	1/2-20UNF-2A螺纹 1/2-20UNF-2A thread
代号 Code	结构件材料 Material for structure part
11	上套为 316SST, 安装环为碳钢 316SST for upper part, carbon steel for installation ring
代号 Code	毛细管长度 Length of capillary
5	1.5米 1.5m
10	3.0米 3.0m
15	4.5, 米 4.5m
20	6.0米 6.0m
25	7.5米 7.5m
30	10米 10m
代号 Code	远传法兰端配件 Accessory parts for remote transmitting flange end
A	1/2-20UNF-2A螺纹 1/2-20UNF-2A thread
C	1/2-20UNF-2A螺纹 1/2-20UNF-2A thread
代号 Code	保护套管 Protection sleeve
11	铠装 300SST 系列不锈钢 Armored 300SST series stainless steel
12	PVC 护套, 铠装 300SST 系列不锈钢 PVC jacket, armored 300SST series stainless steel
1199EFW	11 A 20 A11 典型型号 Typical model

**远传法兰灌充液**  
**Filling liquid for remote transmitting flange**

代号 Code	远传法兰的灌充液 Filling liquid for remote transmitting flange
C10485-0007 01199-0032-0004 01199-0032-0012	DC-200硅油- 稳定范围 -40~+149°C (比重 0.934) DC-200 silicon oil- stability range -40~+149°C (specific weight 0.934) Slyatherm704硅油 稳定范围 -15~+300°C (比重 0.934) Slyatherm704 silicon oil stability range -15~+300°C (specific weight 0.934) 丙油 稳定范围 -45~205°C (比重 1.85) 丙油 stability range -45~205°C (specific weight 1.85)
C10485-0007	— 典型型号
C10485-0007	— Typical model

注\*不能用于测量真空+测真空时温度极限应降低

Note: \* it can not be used to measure the vacuum + the temperature limit shall be lowered when the vacuum is measures

联系人: 姚经理: 13685509377 Email: 115192082@qq.com

# TK3051F卫生型压力变送器

## TK3051F Hygiene Pressure Transmitter

### 优异的产品

绝压和表压测量范围: 0-21至0-5512k Pa 0.2%参  
学精度, 包括线性、迟滞性和重复性影响 量程比  
20:1

稳定性0.1%URL/年

用于CIP/SIP应用场合, 温度上限248° F (140°C)

采用HART通讯协议通讯

基于微处理器的电子线路板

双室结构外壳(水密性电性电子外壳)

模块化设计, 令维修快速且经济

抗射频干扰能力

变送器逐台特性和数字化补偿, 可优化变送器在  
整个工作范围内的性能

外部零点和量程调整

### Excellent product

Absolute pressure and gauge pressure measurement  
range: 0-21 to 0-5512k Pa 0.2% parameter accuracy,  
including linearity, hysteresis and repeatability influence  
Range ratio 20:1

Stability 0.1%URL/year.

Applied in CIP/SIP, upper limit of temperature  
248°F(140°C).

Adopt HART communication protocol.

Electronic circuit board based on micro processor

Modular design, rapid and economical maintenance .

Ability to withstand radio frequency interference .

Characterization of the transmitters one by one and  
digital compensation, able to optimize the performance  
within the whole operation range.

External zero point and range adjustment

Design for professional hygiene application .

### 专业卫生型应用场合设计

### Design for professional hygiene application

符合卫生标准

In line with hygiene standards

安装接口方式: 2英寸

Installation interface method: 2 inches

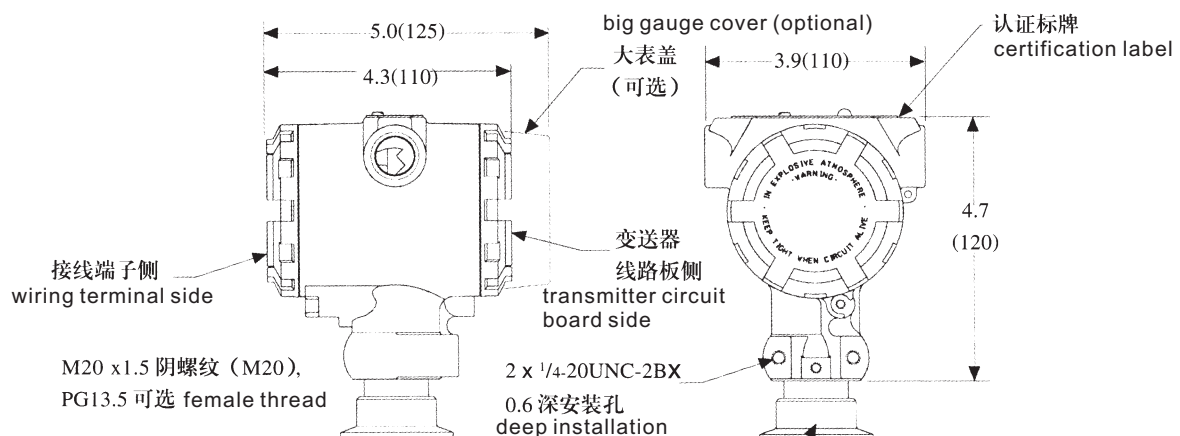
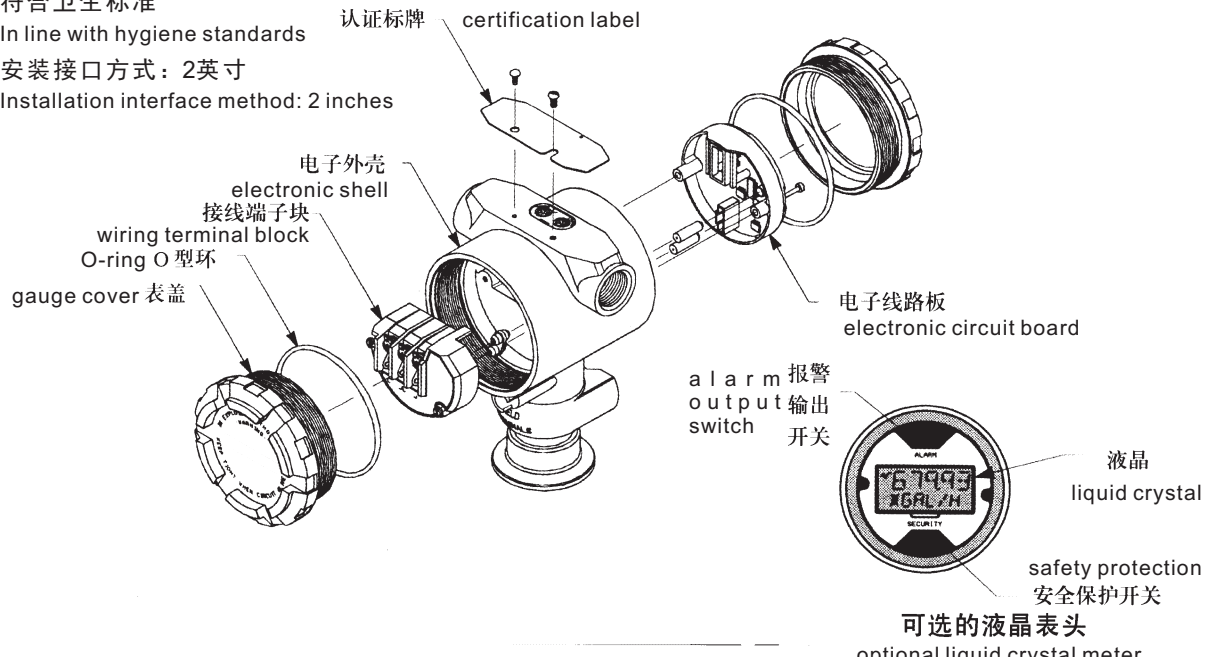

注释:

尺寸单位为英寸 (毫米)

note: the size unit is inch (mm)

## 简介

3051F卫生型压力变送器符合卫生标准，产品接触表面为CIP清洗而设计，结构件材料符合卫生要求。

### 应用

3051F型小巧、稳定、可靠，是食品和制药行业的理想产品，可直接安装在过程管线或罐上，无需支架。过程温度上限为140℃，令3051F型变送器适用于有高温蒸汽清洗的场合。

## Introduction

3051F hygiene pressure transmitter meets the hygiene standards. The product contact face is the designed for CIP cleaning and the material of structural part meets the hygiene standards.

### Application

Being small, stable and reliable, 3051F product is the ideal product for food and pharmaceutical industries and it can be installed directly on the process pipeline or cans without requiring frames. The upper limit of process temperature is 140°C so that the 3051F transmitter is able to be applied to high temperature steam cleaning.

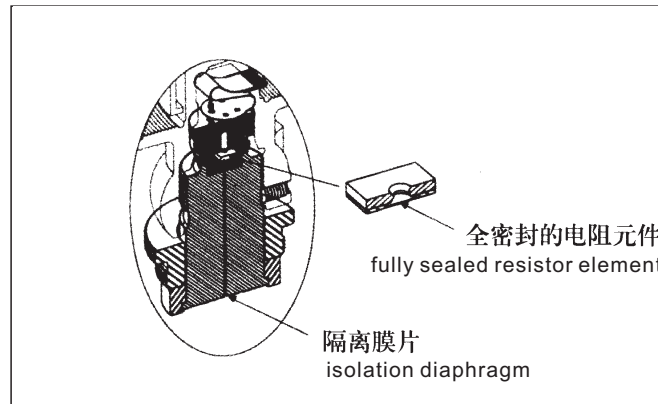

## 规格

### 应用场合

液体、气体、蒸汽和高粘度应用场合。

### 量程

量程 Range	最小量程 (智能) Min. Range (Intelligent)	UPL/最大量程/传感器上限 UPL/MAX. Range/Upper Limit of Sensor
1	10.3kPa (103mbar)	200kPa (2.06bar)
2	51.7kPa (517mbar)	1034kPa (10.34bar)
3	276kPa (2.76bar)	2068kPa (20.68bar)

**输出:** 4-20mA dc/HART数字通讯

**量程比:** 20:1 负载限制

最大回路负载=43.5 (电源电压-10.5)

## Specifications

### Function index

### Applications

Liquid, gas, steam and high viscosity application

### Range

**Output:** 4-20mA dc/HART digital communication

**Range ratio:** 20:1 load limit

Maximum circuit load = 43.5 (power supply voltage -10.5)

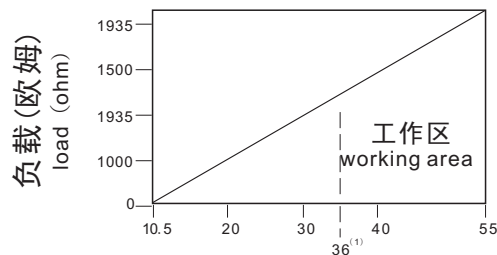

### 电源

要求外部电源供电，无负载时变送器工作电压10.5-36V，反向保护是标准的。

### Power supply

External power supply is required. The operation voltage for the transmitter without load is 10.5-36V. Reverse protection is standard.

联系人: 姚经理: 13685509377 Email: 115192082@qq.com



### 零点正、负迁移

零点可在大气压与量程上限之间(3051FG型)或0kPa与量程上限之间(3051FA型)进行迁移,且校验量程大于或等于最小量程,量程上限值不大于URL(量程上限)。3051FG型不可真空校验。

### 过压极限

量程1: 826.8kPa  
其它: 2URLh

### 温度极限

过程: -4至284°F(-20至140°C)  
环境: -4至185°F(-20至85°C)  
贮存: -22至185°F(-30至85°C)

过程温度高于185°F(85°C),要求环境温度极限降低超出值的1/1.5。

$$\text{最大环境温度(}^{\circ}\text{C)} = 85 - \frac{(\text{过程温度} - 85^{\circ}\text{C})}{1.5}$$

$$\text{最大环境湿度(}^{\circ}\text{F)} = 185 - \frac{(\text{过程温度} - 85^{\circ}\text{C})}{1.5}$$

**湿度极限:** 0~100%相对湿度

**容积变化量:** 小于0.00042cm<sup>3</sup>

**启动时间:** 2秒,无需预热

### 故障报警

如自诊断出传感器或微处理故障,变送器则驱动输出一个高或低的报警信号以提醒用户。高或低的报警方式由用户改变变送器的跳线插针术选择。报警输出值取决于变送器的工厂组态方式:是标准操作还是符合NAMUR的操作。

### 标准操作

线性输出:  $3.9 \leq I \leq 20.8$   
故障高:  $I \geq 21.75\text{mA}$   
故障低:  $I \leq 3.75\text{mA}$

### 符合NAMUR的操作

线性输出:  $3.8 \leq I \leq 20.5$   
故障高:  $I \geq 22.5\text{mA}$   
故障低:  $I \leq 3.6\text{mA}$

### 变送器安全保护

启动变送器安全保护功能可防止对变送器组态的修改,包括本机零点和量程调整功能。调整内部的安全保护开关可启动保护功能。

### 功能指标

(零基量程,参考条件,316SST隔离膜片)

### 参考精度

±0.2%校验量程,包括线性、迟滞性和重复性影响

### 环境温度影响(每100°F(56°C)影响)

±(0.3%URL+0.3%量程), -40至185°F(-40至85°C)

### 稳定性

±0.10%URL, 12个月

### 时间响应

时间响应 时间常数小于200毫秒(阶跃压力变化输出达到63.2%的响应时间)

### Zero point positive and negative shift

The zero point can shift between the barometric pressure and the upper limit of range (3051FG type) or between 0kPa and upper limit of range (3051FA type) and the check range is larger than or equal to the minimum range. The upper limit of the range shall not be larger than URL (upper limit of the range). 3051FG transmitter can not be checked with vacuum.

### Overpressure limit

Range 1: 826.8kPa  
Others: 2URL

### Temperature limit

Process: -4 to 284°F(-20 to 140°C)  
Environment: -4 to 185°F(-20 to 85°C)  
Storage: -22 to 185°F(-30 to 85°C)

When the process temperature is higher than 185°F(85°C), it is required that the reduction of the ambient temperature limit shall exceed 1/1.5 of the value.

$$\text{Maximum ambient temperature(}^{\circ}\text{F)} = 185 - \frac{(\text{process temperature} - 85^{\circ}\text{C})}{1.5}$$

$$\text{Maximum ambient temperature and humidity(}^{\circ}\text{F)} = 185 - \frac{(\text{process temperature} - 85^{\circ}\text{C})}{1.5}$$

**Temperature limit:** 0~100% relative humidity

**Volume change:** smaller than 0.00042cm<sup>3</sup>

**Start time:** 2 seconds without preheating

### Fault alarm

When the sensor or the microprocessor is self-diagnosed with fault, the transmitter will drive one high or low alarm signal to alarm the customer. The high or low alarm method is selected by the user by changing the jumper insertion technology. The alarm output value depends on the plant configuration method for the transmitter: standard operation or operation in line with NAMUR.

### Standard operation

Linear output:  $3.9 \leq I \leq 20.8$   
Fault high:  $I \geq 21.75\text{mA}$   
Fault low:  $I \leq 3.75\text{mA}$

### Operation in line with NAMUR

Linear output:  $3.8 \leq I \leq 20.5$   
Fault high:  $I \geq 22.5\text{mA}$   
Fault low:  $I \leq 3.6\text{mA}$

### Safety protection of transmitter

The safety protection function of the transmitter can prevent the transmitter configuration from changing, including the zero point and range adjustment function for the machine. The adjustment of internal safety protection switch can start the protection function.

### Function index

(zero base range, reference conditions, 316SST isolation diaphragm)

### Reference accuracy

±0.2% calibration range, including linearity, hysteresis and repeatability influence

### Environmental temperature influence

#### (influence of each 100°F(56°C))

±(0.3%URL+0.3% range), -40 to 185°F(-40 to 85°C)

### Stability

±0.10%URL, 12 months

### Time response

Time constant smaller than 200 milliseconds (the response time for the step pressure change output to reach 63.2%)

联系人: 姚经理: 13685509377 Email: 115192082@qq.com

#### 振动影响

小于±0.10%URL, 振动测试条件: 峰-峰值4mm(5-15Hz)  
加速度2g(15-150Hz), 及1g(150~2000Hz)

#### 电源影响

小于±0.01%校验量程/伏

#### 安装位置影响

零点最多漂移0.3kPa, 可修正掉。无量程影响。

#### 射频干扰(RFI)影响

<±0.25%URL, 在20~100MHz, 30伏/米场强下, 引线在导线管内; <±0.25%URL, 10伏/米场强下, 使用不带屏蔽的双绞线(无导线管)

### 机械性能指标

#### 电气接口

1/2-14NPT, M20x1.5(CM20)或PG13.5导线管入口

#### 过程接液件

隔离膜片: 316L不锈钢

过程接头: 316L不锈钢

#### 非接液件

电子外壳: 低铜铝, NEMA 4X, IP65, IP67

喷涂: 聚氨酯

表盖O型环: 丁腈橡胶

重量: 约1.24公斤

#### Vibration influence

Smaller than ±0.10%URL, vibration test conditions: peak-peak value 4mm(5-15Hz)  
Acceleration 2g(15-150Hz) and 1g(150~2000Hz)

#### Power supply influence

Acceleration 2g(15-150Hz) and 1g(150~2000Hz)

#### Installation position influence

Maximum drift of zero point is 0.3kPa and it can be corrected. No range influence.

#### Radio frequency interference (RFI) influence

<±0.25%URL, under 20~100MHz, 30 volts/meter field strength, the leading wire is in the wire conduit; under <±0.25% URL, 10 volts/meter field strength, use non-shielded twisted pair (without wire conduit)

### Mechanical performance index

#### Electrical interface

1/2-14NPT, M20x1.5(CM20) or PG13.5 wire conduit entry

#### Process liquid connection part

Isolation diaphragm: 316L stainless steel

Process joint: 316L stainless steel

#### Non liquid connected part

Electronic shell: low copper aluminum, NEMA 4X,

IP65, IP67

Spray: PU

Gauge cover O-ring: nitrile butadiene rubber

Weight: about 1.24 kilograms

联系人: 姚经理: 13685509377 Email: 115192082@qq.com

# 3051F型订货信息表

## 3051F Type Order Information

型号 Model	产品描述 Product Description													
3051FA	卫生型绝压变送器 Hygiene absolute pressure transmitter													
3051FG	卫生型表压变送器 Hygiene gauge pressure transmitter													
代码 Code	量程 Range													
1	0-200kPa (0-2bar)	<table border="1" style="font-size: small;"> <thead> <tr> <th>量程 Range</th> <th>最小量程 (智能) Minimum range (intelligent)</th> <th>UPL/最大量程 / 传感器上限 UPL/ maximum range / sensor cap</th> </tr> </thead> <tbody> <tr> <td>1</td> <td>10.3kPa (103mbar)</td> <td>200kPa (2.06bar)</td> </tr> <tr> <td>2</td> <td>51.7kPa (517mbar)</td> <td>1034kPa (10.34bar)</td> </tr> <tr> <td>3</td> <td>276kPa (2.76mbar)</td> <td>2068kPa (20.68bar)</td> </tr> </tbody> </table>	量程 Range	最小量程 (智能) Minimum range (intelligent)	UPL/最大量程 / 传感器上限 UPL/ maximum range / sensor cap	1	10.3kPa (103mbar)	200kPa (2.06bar)	2	51.7kPa (517mbar)	1034kPa (10.34bar)	3	276kPa (2.76mbar)	2068kPa (20.68bar)
量程 Range	最小量程 (智能) Minimum range (intelligent)		UPL/最大量程 / 传感器上限 UPL/ maximum range / sensor cap											
1	10.3kPa (103mbar)		200kPa (2.06bar)											
2	51.7kPa (517mbar)		1034kPa (10.34bar)											
3	276kPa (2.76mbar)	2068kPa (20.68bar)												
2	0-1030kPa (0-10.3bar)													
3	0-5515kPa (0-55.15bar)													
代码 Code	输出 Output													
S	4-20mA/DC/HART数字通讯 4-20mA/DC/HART digital communication													
代码 Code	结构件材料 Material of structure part	隔离膜片 Isolation diaphragm												
2D	316SST	316SST												
代码 Code	过程接口 Process interface													
F	2英寸 Tri-clamp 接口 2-inch Tri-clamp interface													
代码 Code	导线管入口螺纹 Entry thread of wire conduit													
2	M20X1.5 (CM20)													
代码 Code	表头 (选项) Meter (optional)													
M5	液晶表头 Liquid crystal meter													
代码 Code	危险场所认证 Dangerous site certification													
E5	本安 Intrinsic safety I all CT4/CT6													
K5	隔爆 Explosion suppression d II CT4/CT6													
典型型号 : 30 Typical mode: 30	1FG 2 S 2D F 1													

### 校验

变送器由工厂按用户指定量程校验。如果不指定校验范围，则按变送器所选量程的最大测量范围校验。校验在环境温度和常压下进行。

### Calibration

The transmitter shall be calibrated by the plant according to the amount designated by the user. When the calibration range is not specified, it shall be calibrated according to the maximum measurement range of the selected range. The calibration is conducted with ambient temperature and normal pressure.

联系人: 姚经理: 13685509377 Email: 115192082@qq.com

# TK3051P高温防腐型压力变送器

## TK3051P High Temperature Anti-Corrosion Pressure Transmitter

### 概述

该型号是TK3051T型标准智能压力变送器的变形产品，在TK3051T的基础上加装密封隔离膜结构。过程连接方式为螺纹旋入式，平型法兰式、延伸凸型法兰式及焊接螺纹式。法兰式隔离膜片可用多种合金材料和塑料涂层合金制作。加装温度隔离器或毛细管，可耐300℃介质。极大扩展了应用范围，适用于高温、强腐蚀和粘度大介质的测量，除温度影响指标与TK3051T型有所不同外，其它性能基本一致。

### General

This model is the variant of TK3051T standard intelligent pressure transmitter, which has seal isolation diaphragm structure added on TK3051T. The process connection type is thread screw-in type, flat flange type, extended convex flange and welded thread type. The flange type isolation diaphragm can be made of multiple kinds of alloy material and plastic coated alloy. With temperature isolator or capillary, it is able to withstand 300℃ medium. It expands greatly the application range and suitable for measurement of medium with high temperature, strong corrosion and large viscosity. Its performance is basically the same as TK3051T type except the temperature influence index.

### 测量范围

#### TK3051P型

##### 相对压力:

最大测量范围0~40MPa  
最小测量范围0~4kPa

##### 绝对压力:

最大测量范围0~4MPa  
最小测量范围0~50kPa

##### 负相对压力:

最大测量范围-0.1MPa~39.9MPa  
最小测量范围-50kPa~0kPa

### Measurement range

#### TK3051P type

##### Relative pressure:

Maximum measurement range 0~40MPa  
Minimum measurement range 0~4kPa

##### Absolute pressure:

Maximum measurement range 0~4MPa  
Minimum measurement range 0~50kPa

##### Relative pressure:

Maximum measurement range -0.1MPa~39.9MPa  
Minimum measurement range -50kPa~0kPa

### TK3051P高温防腐型连接件数据

#### Data of TK3051P high temperature anti-corrosion connection parts

选型代码 Selection code	链接螺纹						密封隔离膜片				
	公称直径 G	公称压力 PN	直径 d1 mm	直径 d mm	直径 d2 mm	螺纹长度 X1 mm	外侧平面 间距 SW mm	膜片直径 dm mm	推荐最小 测量值 mm	高度 A mm	总质量 kg
AF	G1/A	40MPa	29	39	[sw41]	21	41	27	1	175	1.6
AG	G11/2A	40MPa	42	54.5	58	30	41	38	0.04	177	2.3
AR	G2A	40MPa	56	68	78	30	60	44	0.01	182	3.3

### 隔膜材料[一]

过程连接件螺纹部分不锈钢1 Cr 18Ni9Ti  
[特殊要求可供不锈钢316L, 哈氏合金C276]  
波纹膜片不锈钢316L  
哈氏合金C276

### Diaphragm material [I]

Partial stainless steel for threads of process connection parts  
[stainless steel 316L, Hastelloy C276 can be provided for special requirements]  
Corrugated diaphragm stainless steel 316L  
Hastelloy C276

### 温度影响[一]

隔离膜片G1A +1200Pa/10K  
隔离膜片G11/2A +600Pa/10K  
隔离膜片G2A +300Pa/10K

### Temperature influence [I]

Isolation diaphragm G1A +1200Pa/10K  
Isolation diaphragm G11/2A +600Pa/10K  
Isolation diaphragm G2A +300Pa/10K

### 过程连接[一]

外螺纹旋入式焊接密封隔膜结构连接  
螺纹标准G1A, G11/2A, G2A PN40MPa  
[特殊要求可供NPT标准]

### Process connection [I]

External thread screw-in welded seal diaphragm structure connection  
Thread standard G1A, G11/2A, G2A PN40MPa  
[NPT standards can be provided for special requirements]

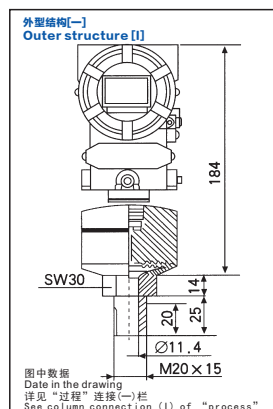



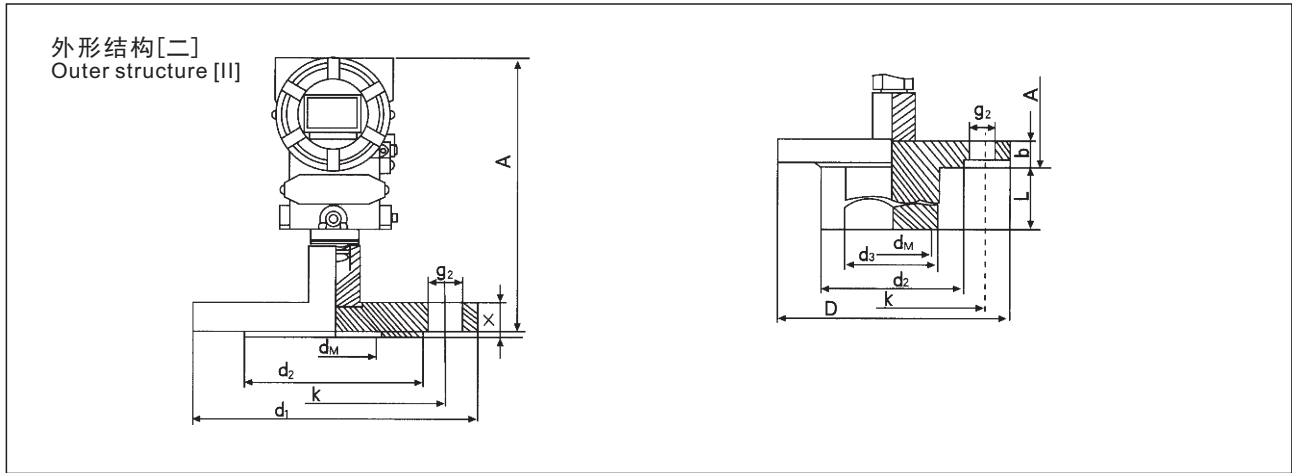

### 过程连接[二]

平法兰或延伸平法兰式焊接密封隔膜结构连接。  
法兰标准 GB9123-88

TK3051P高温防腐型DN50、DN80、PN1/4MPa  
DN25、DN50、PN6/40MPa

[结构见上图数据见下表]

[特殊要求可供DIN、ANSI标准]

### Process connection [II]

Flat flange or extended flat flange type welded seal diaphragm structure connection  
Flange standard GB9123-88

TK3051P high temperature anti-corrosion DN50, DN80, PN1/4MPa DN25, DN50, PN6/40MPa

[see the drawing above for structure and see the following table for data.]

[standards DIN and ANSI can be provided for special requirements]

### TK3051P高温防腐型连接件数据 Data of TK3051P high temperature anti-corrosion connection parts

选型代码 Selection code			DK	AK	BK	CK	SU	NU	NU	PU
法兰 Flange	公称直径 Nominal diameter	DN	50	50	50	50	80	80	80	80
	公称压力 Nominal pressure	PN MPa	1/4	1/4	1/4	1/4	1/4	1/4	1/4	1/4
	压径 [D] Pressure diameter	d1 mm	165	165	165	165	200	200	200	200
	厚度 [X] Thickness	b mm	20	20	20	20	24	24	24	24
	延伸膜长度 Length of extended film	l mm	-	50	100	200	-	50	100	200
	延伸膜直度 Straightness of extended film	d3 mm	-	48.3	48.3	48.3	-	76.5	76.5	76.5
	凸台直径 Diameter of boss	l mm	99	99	99	99	132	132	132	132
螺孔 Thread	孔数 Number of holes		4	4	4	4	8	8	8	8
	孔径 Hole diameter	g2 mm	18	18	18	18	18	18	18	18
	孔中心距 Center distance of holes	K mm	125	125	125	125	160	160	160	160
密封隔离 膜片 Sealing isolation diaphragm	膜片直径 Diaphragm diameter	dm mm	46	46	46	46	70	70	70	70
	高度 Height	A mm	200	204	204	204	204	204	204	204
	总重量 Total weight	kg	3.72	4.48	8.11	3.72	6.23	6.23	4.48	4.48

### 3051P型连接件数 Number of 3051P type connection parts

FC	FD	FM	FN
25	25	25	25
5/10	15/25	5月15日	15/25
125	150	165	215
17.5	20	20	20
-	-	-	-
-	-	-	-
50.8	50.8	92.1	92.1
4	4	8	8
20	26	20	26
89	101.5	127	165
28	28	46	46
204	204	204	204
2.9	5.45	11.4	16.9

### 外型结构[一]

过程连接件：  
平法兰，延伸平法兰部分，不锈钢  
1Cr18Ni9Ti [特殊要求可供不锈钢316L]

### 温度影响[一]

TK3051P型：  
DN25 2kPa/10K; DN50 300Pa/10K  
DN50 [包括延伸50mm、100mm、200mm] 300Pa/10K  
DN80 [包括延伸50mm、100mm、200mm] 200Pa/10K

### Outer structure [I]

Process connection parts:  
Flat flange, extended flat flange part, stainless steel  
1Cr18Ni9Ti [stainless steel 316L can be provided for special requirements]

### Humidity influence 1 [I]

TK3051P type:  
DN25 2kPa/10K; DN50 300Pa/10K  
DN50 [including extension 50mm, 100mm, 200mm] 300Pa/10K  
DN80 [including extension 50mm, 100mm, 200mm] 200Pa/10K

联系人: 姚经理: 13685509377 Email: 115192082@qq.com

### 外形结构[三]

### Outer structure [III]

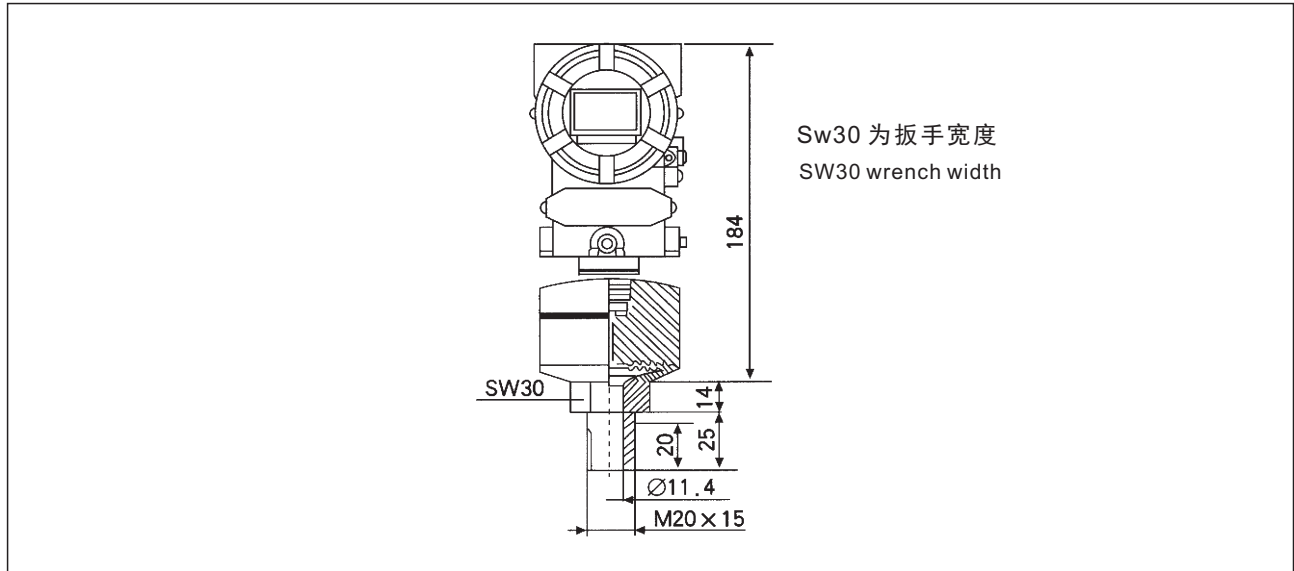

### 过程连接[三]

焊接式外螺纹焊接密封隔膜结构连接  
螺纹标准：外螺纹G1/2A内孔  $\phi 11.4\text{mm}$   
PN4MPa [特殊要求可供NPT标准]

### Process connection [III]

Welded external thread welded seal diaphragm structure connection.  
Thread standard: external thread G1/2A inner hole  $\phi 11.4\text{mm}$ .  
PN4MPa [NPT standard can be provided for special requirements]

### 隔膜材料[三]

过程连接件焊接螺纹部分：不锈钢  
1Cr18Ni9Ti [特殊要求可供不锈钢316L、哈氏合金C-276]  
隔离波纹膜片部分：不锈钢316L、哈氏合金C276、钽、不锈钢316L带PTFE涂层。  
隔离波纹膜片部分：不锈钢316L哈氏合金C276、钽及不锈钢316带PTFE涂层。

### Diaphragm material [III]

Welded thread part of process connection parts: stainless steel  
1Cr18Ni9Ti [stainless steel 316L and hastelloy C-276 can be provided for special requirements]  
Isolation corrugated diaphragm part: stainless steel 316L, hastelloy C 276, tantalum, stainless steel 316L with PTFE coating

### 温度影响[三]

200Pa/10K

### Temperature influence [III]

200Pa/10K

联系人：姚经理：13685509377 Email: 115192082@qq.com

# TK3051P高温防腐型压力变送器

## TK3051P High Temperature Anti-Corrosion Pressure Transmitter

型号 Model	变送器类型 Transmitter Type	
R	标准型 Standard type	
G	本安型 ia II CT4/T6 Intrinsic safety type ia II CT4/T6	
D	隔爆型 dII CT4/T6 Explosion suppression type dII CT4/T6	
代号 Code	外壳、显示 Shell, display	
3	铝外壳, 电缆孔 M20×1.5 M20×1.5带数字显示器 Aluminum shell, cable hole, M20×1.5 M20×1.5 with	
4	铝外壳] 电缆孔 M20×1.5 Aluminum shell, cable hole, M20×1.5	
9	约定的特殊要求 Stipulated special requirements	
代号 Code	传感器标准量程 [量程比 10:1] Standard range of sensor [range rate 10:1]	最大过压
	—表压传感器— Gauge pressure sensor	Maximum
1F	传感器 40kPa Sensor 40kPa	1MPa
1K	传感器 200kPa Sensor 200kPa	2MPa
1P	传感器 1MPa Sensor 1MPa	4MPa
1S	传感器 4MPa Sensor 4MPa	6MPa
1G	传感器 7MPa Sensor 7MPa	10MPa
1L	传感器 10MPa Sensor 10MPa	15MPa
1X	传感器 20MPa Sensor 20MPa	30MPa
1H	传感器 40MPa Sensor 40MPa	60MPa
	—绝压传感器— Gauge pressure sensor	
2F	传感器 40kPa Sensor 40kPa	1MPa
2K	传感器 200kPa Sensor	2MPa
2P	传感器 1MPa Sensor	4MPa
2S	传感器 4MPa Sensor	6MPa
代号 Code	标定、压力单位 Calibration, pressure unit	
2	0~标准量程, 标定 kPa/MPa 0~standard range, calibration kPa/MPa	
9	约定的特殊要求 Stipulated special requirements	
代号 Code	电子部件、通讯协议 Electronic part, communication protocol	
H	输出 4~20mA, HART协议 Output 4~20mA, HART protocol	
S	输出 4~20mA Output 4~20mA	
Y	约定的特殊要求 Stipulated special requirements	
代号 Code	隔膜中介液 Diaphragm medium liquid	
A	硅油 Silicon oil	
G	高温油+温度隔离器 100mm High temperature oil + temperature isolator 100mm	
K	高温油, 1m毛细管 High temperature oil, 1m capillary	
L	硅油, 1m毛细管 High temperature oil, 1m capillary	
Y	约定的特殊要求 Stipulated special requirements	
代号 Code	过程连接标准 Process connection standards	
AF	外螺纹 G1A, 推荐最小测量值 200KPa Outer thread G1A, recommended minimum measurement value 200KPa	
AG	外螺纹 G11/2A, 推荐最小测量值 40KPa Outer thread G11/2A, recommended minimum measurement value 40KPa	
AR	外螺纹 G2A, 推荐最小测量值 10KPa Outer thread G2A, recommended minimum measurement value 10KPa	
CA	焊接螺纹外螺纹 G1/2A内孔 φ11.4mm Welded thread outer thread G1/2A inner hole φ11.4mm	
DK	平法兰 GB9123-88 DN50, PN1MPa/4MPa Flat flange GB9123-88 DN50, PN1MPa/4MPa	
SU	平法兰 GB9123-88 DN80, PN1MPa/4MPa Flat flange GB9123-88 DN80, PN1MPa/4MPa	
AK	平法兰 GB9123-88 DN50, PN1MPa/4MPa, 延伸50mm Flat flange GB9123-88 DN50, PN1MPa/4MPa, extend 50mm	
BK	平法兰 GB9123-88 DN50, PN1MPa/4MPa, 延伸100mm Flat flange GB9123-88 DN50, PN1MPa/4MPa, extend 100mm	
OK	平法兰 GB9123-88 DN50, PN1MPa/4MPa, 延伸200mm Flat flange GB9123-88 DN50, PN1MPa/4MPa, extend 200mm	
MU	平法兰 GB9123-88 DN50, PN1MPa/4MPa, 延伸50mm Flat flange GB9123-88 DN50, PN1MPa/4MPa, extend 50mm	
NU	平法兰 GB9123-88 DN80, PN1MPa/4MPa, 延伸100mm Flat flange GB9123-88 DN80, PN1MPa/4MPa, extend 100mm	
PU	平法兰 GB9123-88 DN80, PN1MPa/4MPa, 延伸200mm Flat flange GB9123-88 DN80, PN1MPa/4MPa, extend 200mm	
YY	约定的特殊要求 Stipulated special requirements	
代号 Code	波纹膜片材料 Corrugated diaphragm material	
1	不锈钢 316L Stainless steel 316L	
2	哈氏合金 C276 Hastelloy C276	
5	钽 tantalum	
7	不锈钢 316L带PTFE涂层 Stainless steel 316L with PTFE painting	
9	约定的特殊要求 Stipulated special requirements	
TK3051P- R 3 1F 2 H A DK 1		

安装附件  
 安装支架 .....G  
 标准电缆密封套  
 外螺纹M20×1.5 .....T  
 隔爆电缆密封套  
 外螺纹M20×1.5 .....T2  
 用户选用附件, 请在选型代码后的括号内注明所要附件的代码。

Installation accessories  
 Installation frame .....G  
 Standard cable seal cartridge  
 External screw M20×1.5 .....T  
 Explosion suppression cable seal cartridge  
 External screw M20×1.5 .....T2  
 When the user chooses accessory, please indicate the code of the required accessory in the bracket after the selection code

# TK208、TK316系列扩散硅变送器

## TK208, TK316 series diffusion silicon transmitter



TK316压力变送器  
TK316 pressure transducer



TK208压力变送器  
TK208 pressure transducer

### 一、概述

TK208、TK316系列扩散硅变送器，选取进口高性能隔离式扩散硅传感器，采用国际上的先进制造工艺，具有同类进口变送器的坚固性和可靠性，适用于各种工业领域中腐蚀性介质的表压、绝压和负压的检测。

### I. General

TK208 and TK316 series diffusion silicon transmitter uses imported high performance isolation diffusion silicon sensor and internationally advanced manufacturing process. It has the rigidity and reliability of similar imported transmitter and is applicable to detection of gauge pressure, absolute pressure and negative pressure of the corrosive medium in the industrial filed.

### 二、特点

性能价格比高  
过程直接安装  
温度特性好  
综合精度高

### II. Characteristics

High cost performance  
Direct process installation  
Good temperature characteristics  
High overall accuracy

### 三、主要技术参数

电源：24VDC 输出4~20mA二线制  
零位可调范围：±50%  
量程调节比：3:1以上  
量程范围：-100kPa~0~60MPa  
负载特性：负载在0~600Ω内(24VDC供电)维持恒流输出  
显示：5位LCD, 工程单位%等  
防爆型d II CT4, 本安型ia II CT6  
过压极限：2倍于上限压力  
温度范围：过程：-20~60℃  
精度等级：±0.2%, ±0.5%  
稳定性：±0.2%F·S  
重量：约1kg  
Tk型扩散硅压力变送器选型表

### III. Main technical parameters

Power supply: 24VDC output, 4-20mA two-wire system  
Adjustable range of zero position: ±50%  
Adjustment ration of the range: above 3: 1  
Range scope: -100kPa~0~60MPa  
Load characteristics: constant current output is maintained when the load in within 0~600Ω (24VDC power supply)  
Display: 5 LCD, engineering unit, etc.  
Explosion suppression d II CT4, intrinsic safety ia II CT6  
Overpressure limit: twice the upper limit pressure  
Temperature range: process: -20~60℃  
Accuracy class: ±0.1%, ±0.5%  
Stability: ±0.2%F·S  
Weight: about 1kg  
TK Diffusion Silicon Pressure Transmitter Selection

联系人：姚经理：13685509377 Email: 115192082@qq.com

# TK型扩散硅压力变送器选型表

## TK Diffusion Silicon Pressure Transmitter Selection

**选型表**  
**Selection table**

型号Model	变送器类型 Transmitter type
TK208	压力变送器 Pressure transmitter
TK316	压力变送器 Pressure transmitter
代号Code	过程连接膜片及材料 Process connection diaphragm and material
1	不锈钢316L膜片/过程1Cr18Ni9Ti Stainless steel 316L diaphragm/process 1Cr18Ni9Ti
2	钽膜片/过程316L Tantalum diaphragm/process 316L
3	陶瓷膜片/过程316L Ceramic diaphragm/process 316L
代号Code	过程连接标准 Process connection standard
R	外螺纹G1/2A Outer screw G1/2A 内孔 φ8mm Inner hole φ8mm
B	外螺纹M20×1.5 内孔 Outer screw M20×1.5 Inner hole
Y	约定的特殊要求 φ8mm specified special requirements
代号Code	密封圈材料 Seal ring material
1F	氟橡胶 [低温限制-20℃] Fluoride rubber [low temperature limitation-20℃]
3F	氟硅橡胶 [低温限制-20℃] Fluorinated silicone rubber [low temperature limitation-20℃]
4F	EPDM [低温限制-40℃] EPDM [low temperature limitation-40℃]
9Y	Y约定的特殊要求 Special requirements of agreement
代号Code	信号输出 Signal output
2	模拟信号4-20mA二线 Analog signal 4-20mA two wire
9	约定的特殊要求 Stipulated special requirements
代号Code	外壳显示 Shell display
5	铝外壳, 电缆孔M20×1.5 Aluminum shell, cable hole M20 * 1.5
9	数字显示31/LCD现场压力值(BPS316不配) Digital display 31/ LCD, pressure value on site (BPS316 not provided)
N	无显示 No show
代号Code	精度等级 Accuracy class
3	0.20%
6	0.50%
代号Code	量程、压力单位 Range, pressure unit
G1G	表压 Gauge pressure
G2G	绝压 Absolute pressure
Y	负压 Negative pressure
代号Code	泵压专用 Special pump pressure
X	阻尼装置 Damping device
TK208 1 B 1F 5 6 G1G	

安装附件  
 安装支架 .....G  
 标准电缆密封套  
 外螺纹M20×1.5 .....T  
 隔爆电缆密封套  
 外螺纹M20×1.5 .....T2  
 用户选用附件, 请在选型代码后的括号内注明所要附件的代码。  
 例: TK208 1 B 1F 5 6 G1G

Installation accessories  
 Installation frame .....G  
 Standard cable seal cartridge  
 Outer thread M20×1.5 .....T  
 Explosion proof cable seal cartridge  
 Outer thread M20×1.5 .....T2  
 When the user selects the accessories, please indicate the code of the required accessories in the bracket after the selection code.  
 E.g.: TK208 1 B 1F 5 6 G1G

联系人: 姚经理: 13685509377 Email: 115192082@qq.com



# TY-YB静压式/TK-HB导压式液位变送器

## TK-YB Static Pressure Pressure /TK-HB Guiding Liquid Level Transmitter



TY-YB系列  
TY-YBseries



TK-HB系列  
TK-HBseries

### 一、TY-YB静压式液位变送器

静压式液位变送器采用德国SENSE压力传感器原装组件生产，主要用于城市给排水、水处理厂、水库、河流、海洋、储油罐、及石油、化工、电力等部门的液位测量，被测介质可以是水、油、碱性液体。仪表输出二线制4~20mADC标准电流信号，具有技术先进、精度高、质量稳定可靠，安装使用方便等优点，是一种过程检测控制系统中理想的液位仪表。

#### 主要技术参数

测量范围：0.3~100m（由用户自选）  
精度：0.1级、0.5级  
工作温度：-20~80℃  
输出信号：二线制4~20mADC  
电源电压：24VDC， $\leq \pm 1.0\%$ PS  
负载能力：0.600Ω  
相对湿度： $\leq 85\%$   
防护等级：IP68  
防爆标志：ExiaII CT4~6

### 二、TK-HB导压式液位变送器

TY-HB导压式（静压）液位变送器是一种结构独特、实用性很强的液位仪表。它与传统的投入式液位计的最大不同点在于传感器不直接和介质接触。是通过导压管内空气将液位的高低变化，传到传感器上。这样就避免了传感器的堵塞，损害腐蚀，大大延长了仪表的使用寿命。因其独特的设计，使之特别适用于测量高温、高粘度、混浊、强腐蚀性液体。如重油、渣油、浆料、硫酸、污水等，是传统投入式液位变送器的理想替代品，导压式液位变送器广泛应用于石化、钢铁、能源、食品、污水处理、制药、自来水等行业的敞口容器的液位测量。

导压式液位变送器应用：工业现场液位测量与控制、城市供水及污水处理、石油、化工、电厂、水文监测、水库、大坝、水电建设等领域的液位的测量与控制。

### I. TY-YB Transmitter

Static pressure liquid transmitters are manufactured with original assemblies of German SENSE pressure sensors. It is mainly used for level measurement in urban water supply and drainage, water treatment plant, reservoir, river, ocean, oil tank, and departments like petroleum, chemical engineering and electric power. The medium being measured can be water, oil, and alkaline liquid. The instrument outputs two-wire system of 4~20mADC standard current signal. Being advanced in technology, high in accuracy, stable and reliable in quality and convenient to install and use, it is an ideal liquid level instrument in process detection and control system.

#### Main technical parameters

Measurement range: 0.3~100m(selected by user himself)  
Working temperature: -20~80℃  
Accuracy: 0.1, 0.5  
Output signal: two-wire system 4~20mADC  
Power supply voltage: 24VDC,  $\leq \pm 1.0\%$ PS  
Load capacity: 0.600Ω  
Relative temperature:  $\leq 85\%$   
Protection class: Ip68  
Explosion proof sign: ExiaII CT4~6

### II. TK-HB air guide type liquid level transmitter

TK-HB air guide type liquid level transmitter TK-HB pressure (static pressure) liquid level transmitter is a liquid level instrument with unique structure, strong practicability. The biggest difference between it and the traditional input type liquid level gauge is that the sensor is not directly contact with the medium. The liquid level is changed by the air in the air guide pipe, and the air is transferred to the sensor. In this way, the blockage of the sensor is avoided, the corrosion is damaged, and the service life of the meter is prolonged. Because of its unique design, so that it is particularly applicable to the measurement of high temperature, high viscosity, turbidity, strong corrosive liquid. As of heavy oil and residual oil slurry and sulfuric acid, sewage and other, traditional investment type liquid level transmitter is an ideal substitute of guide type liquid level transmitter is widely used in petrochemical, steel, energy, food, sewage treatment, pharmaceutical, water and other industries of the exposure container liquid level measurement.

Guide pressure liquid level transmitter application: industrial field liquid level measurement and control, urban water supply and wastewater treatment, petroleum, chemical industry, power plants, hydrological monitoring, reservoirs, dams, hydropower construction and in the field of liquid level measurement and control.

联系人：姚经理：13685509377 Email: 115192082@qq.com

# TY-YB型静压式液位变送器选型表

## Type selection table of TY-YB type static pressure type liquid level transmitter

**选型表**  
**Selection table**

型 Model	变送器类型 Transmitter type
TY-YB	静压式 static pressure type
代号 Code	过程连接膜片及材料 Process connection diaphragm and material
1	不锈钢 316L膜片/过程 1Cr18Ni9Ti Stainless steel 316L diaphragm/process 1Cr18Ni9Ti
2	钽膜片/过程 316L Tantalum diaphragm/process 316L
9	陶瓷膜片/过程 316L Ceramic diaphragm/process 316L
代号 Code	过程连接标准 Process connection standard
R	支架 L型 frame L type
B	板状 plate installation
Y	约定的特殊要求 specified special requirements
代号 Code	密封材料 Seal material
1F	缆式 Cable type
3F	杆式 rod type
9Y	约定的特殊要求 specified special requirements
代号 Code	信号输出 Signal output
2	模拟信号 4-20mA 二线 Analog signal 4-20mA two wire
9	智能 HART 协议 Intelligent HART protocol
代号 Code	外壳显示 Shell display
5	铝外壳, 电缆孔 M20×1.5 Aluminum shell, cable hole M20 * 1.5
9	数字显示 31/2 LCD 现场压力值 Digital display 31/2LCD, pressure value on site
代号 Code	精度等级 Accuracy class
3	0.10%
6	0.50%
1	1.00%
代号 Code	防爆等级 Explosion proof class
1	d II CT4 隔离爆 II 类 C 级 T6 组 d II CT4 isolation explosion Category II Class C Group T6
2	ia II CT6 本安型 II 类 C 级 T4 区 ia II CT6 intrinsic safety Category II Class C Group T4
代号 Code	量程、压力单位 Range, pressure unit
A	KPa
B	mH2O
Y	其他 other

安装附件  
 安装支架  
 标准电缆密封套  
 外螺纹 M20×1.5  
 隔爆电缆密封套  
 外螺纹 M20×1.5  
 用户选用附件, 请在选型代码后的括号内注明所要附件的代码。  
 订货时请注明:  
 量程 L=米  
 请注明缆长或杆长 H=米  
 法兰安装式: 请注明法兰规格

installation accessories  
 installation frame  
 standard cable sealing cartridge  
 outer thread M20×1.5  
 Explosion proof cable seal sleeve  
 outer thread M20×1.5  
 When the user selects the accessories, please indicate the code of the required accessories in the bracket after the selection code.  
 Please note during order:  
 Range L= meter  
 Please indicate cable length or rod length H= meter  
 Flange installation type: please indicate the flange specification re Guiding Liquid Level Transmitter

联系人: 姚经理: 13685509377 Email: 115192082@qq.com

# TK-HB型导压式液位变送器选型表

## TK-HB type guide pressure liquid level transmitter selection table

**选型表**  
**Selection table**

型号Model	变送器类型 Transmitter type
TK-HB	导压式 guide pressure type
代号Code	过程连接膜片及材料 Process connection diaphragm and material
1	不锈钢316L膜片/过程1Cr18Ni9Ti Stainless steel 316L diaphragm/process 1Cr18Ni9Ti
2	钽膜片/过程316L Tantalum diaphragm/process 316L
9	陶瓷膜片/过程316L Ceramic diaphragm/process 316L
代号Code	过程连接标准Process connection standard
R	支架 L型 frame L type
B	法兰（用户指定）Flange（User specified）
Y	约定的特殊要求 specified special requirements
代号Code	密封材料 Seal material
1F	钢缆式 Cable type
3F	杆式 rod type
4F	防腐PTFE(与介质接触部分) Corrosion protection PTFE (contact with the medium)
9Y	高温: ≤240℃
代号Code	信号输出 Signal output
2	模拟信号4-20mA二线 Analog signal 4-20mA two wire
9	智能HART协议 Intelligent HART protocol
代号Code	外壳显示 Shell display
5	铝外壳, 电缆孔M20×1.5 Aluminum shell, cable hole M20 * 1.5
9	数字显示31/2 LCD现场压力值Digital display 31/2LCD, pressure value on site
代号Code	精度等级 Accuracy class
3	0.10%
6	0.50%
代号Code	量程、压力单位 Range, pressure unit
A	Kpa
B	mH <sub>2</sub> O
Y	其他other

安装附件  
安装支架  
标准电缆密封套  
外螺纹M20×1.5  
隔爆电缆密封套  
外螺纹M20×1.5  
用户选用附件, 请在选型代码后的括号内注明所要附件的代码。  
订货时请注明:  
量程L=米  
请注明缆长或杆长H=米  
法兰安装式: 请注明法兰规格

installation accessories  
installation frame  
standard cable sealing cartridge  
outer threadM20×1.5  
Explosion proof cable seal sleeve  
outer threadM20×1.5  
When the user selects the accessories, please indicate the code of the required accessories in the bracket after the selection code.  
Please note during order:  
Range L= meter  
Please indicate cable length or rod length H= meter  
Flange installation type: please indicate the flange specification re Guiding Liquid Level Transmitter

联系人: 姚经理: 13685509377 Email: 115192082@qq.com

# TK301一体化浓度/密度变送器

## TK301 Integrated Concentration/Density Transmitter



### 产品简介

TK301智能浓度/密度变送器是一种用于连续在经理测量液体浓度和密度的仪表，可直接用于工业生产过程。

它的独创设计在于采用一个电容式差压传感器以及与其相连的、插入生产过程的一对压力中继器。在两个压力继电器之间有一个温度传感器，用以补偿过程液体的温度变化。一个专用软件利用特定的算法计算密度。

### 应用

制糖和酒精业奶制品业采矿食品加工制浆造纸业酿酒及饮料加工化工，石化，制药。

### 技术提要

精度： $\pm 0.0004\text{g/cm}^3$  ( $\pm 0.10\text{Brix}$ )  
 量程： $0.5\text{g/cm}^3 \sim 5\text{g/cm}^3$

### 电子线路图示

#### 传感器部分 Sensor part

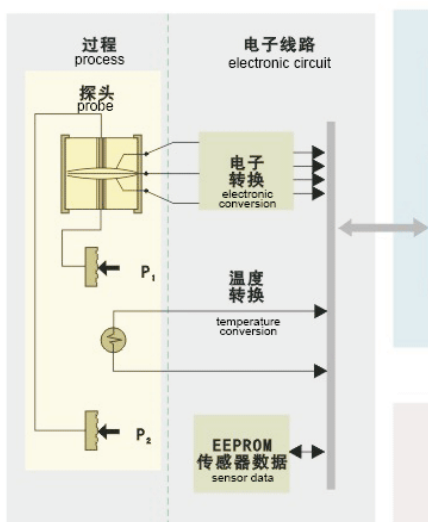

### Product introduction

TK301 intelligent concentration/density transmitter is one instrument measuring continuously the liquid concentration and density and it can be used directly to the industrial production.

Its original design lies in one capacitance differential pressure sensor and one pressure relay connected with it and inserted into the production. There is one temperature sensor between two pressure relays to compensate for the temperature change of the process liquid. One special software uses particular algorithm to calculate the density.

### Application

Sugaring, alcohol industry, dairy industry, mining, food processing, slurring, paper making, brewing, beverage processing, chemical engineering, petrochemical industry and pharmacy.

### Technical summary

Accuracy： $\pm 0.0004\text{g/cm}^3$  ( $\pm 0.10\text{Brix}$ )  
 Range： $0.5\text{g/cm}^3 \sim 5\text{g/cm}^3$

### Electronic circuit diagram

#### 主板部分 Motherboard part

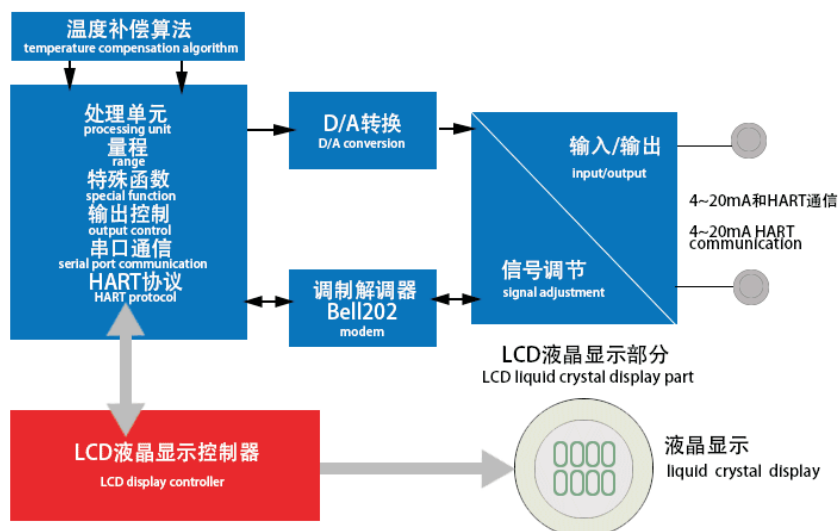

联系人：姚经理：13685509377 Email: 115192082@qq.com

## 选型代码

## Selection code

### 工业型

TK301	工业型密度/浓度变送器 Industrial density/concentration transmitter	
代码 Code	量程 range	最小范围 minimum scope
1	0.5-1.8g/cm <sup>3</sup>	0-0.025g/cm <sup>3</sup>
2	1.0-2.5g/cm <sup>3</sup>	0-0.050g/cm <sup>3</sup>
3	2.0-5.0g/cm <sup>3</sup>	0-0.250g/cm <sup>3</sup>
注: 对浓度单位° Brix, ° Plato, ° GL和° Baume, 应指定代码1 Note: for concentration unit° Brix, ° Plato, ° GL and ° Baume, , code 1 shall be designated.		
代码 Code	触液部分材质 material for part contacting liquid	
H	哈氏合金C276 hastelloy C276	
I	316L不锈钢 316L stainless steel	
Z	其他-指定 others designated	
代码 Code	填充液 filling liquid	
N	Neobee-M20 Propylene Glycol (食品级) (food class)	
D	DC-704 硅油 DC-704 silicon oil	
S	DC200/20 硅油 DC200/20 silicon oil	
G	甘油和水 glycerin and water	
T	Syltherm 800	
Z	其他-指定 others designated	
代码 Code	液晶显示	
0	不带显示	
1	带显示	
代码 Code	电气接口	
O	1/2-14NPT	
A	M20×1.5	
B	Pg13.5DIN	
Z	其他-指定 others designated	
代码 Code	安装 installation	
0	顶 top	
1	侧 side	
代码 Code	过程连接持尺寸、耐压等级和标准 process connection size, withstand voltage class and standard	
5	1	3" 150#ANSIB-16.5
5	2	3" 150#ANSIB-16.5
5	3	3" 150#ANSIB-16.5
A	C	DN80PN25/40 IN2526-FORMD
Z	Z	其他-指定 others designated
代码 Code	其他选项 other options	
H1	316L不锈钢壳体 316L stainless steel shell	
Z2	其他-指定 others designated	
TK301	-	1 1 A - 1 1 1 - 5 1 / . 基本选型示例

若无关选项, 此栏不填。  
no filling in this column when no relevant option

## 尺寸

## Size

### 工业型 Industrial type

尺寸单位mm (英寸)

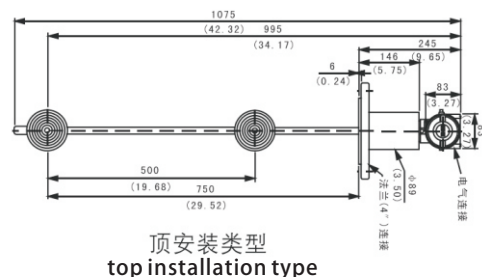
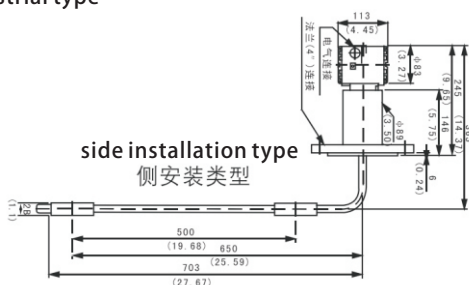



# TK6800电动压差式液位变送器

## TK6800 electric pressure differential liquid level transmitter

采用成熟的压差测量技术，通过特殊的结构设计使TK6800电动压差式液位变送器具有以下特点：  
测量精度高、性能可靠、长期稳定性好，使用方便，广泛适用于电力、石油、化工、冶金、环保、建筑、食品等各行业生产过程的液位测量与控制。  
通用性强：可满足不同温度、压力、介质的液位测量要求，并可应用于腐蚀、高温、高压、冲击等恶劣场合。  
免维护：测量过程无可动部件，不存在机械部件损坏问题，无需维护。  
准确可靠：测量量多样化，使测量更加准确，测量不受环境变化影响，稳定性高，使用寿命长。  
多数应用场所可替代电动浮筒式或射频导纳及雷达式液位变送器。

Mature pressure differential measurement technology is adopted. Special structural design is used so that the TK6800 electric pressure differential liquid level transmitter has following characteristics:

High measurement accuracy, reliable performance, good long term stability, convenient use, widely applicable to liquid level measurement and control in production in industries like electric power, petroleum, chemical engineering, metallurgy, environmental protection, architecture and food.

Highly general use: able to meet the measurement requirements of different temperature, pressure and medium and applicable to harsh conditions with corrosion, high temperature, high pressure and impact.

Maintenance-free: no movable part during measurement, no mechanical part damage, no need for maintenance

Accurate and reliable: diversified measurement, more accurate measurement, not affected by environmental change, high stability, long service life.

In most application cases, it is able to replace the electric buoy or radio frequency admittance and radar liquid level transmitter.

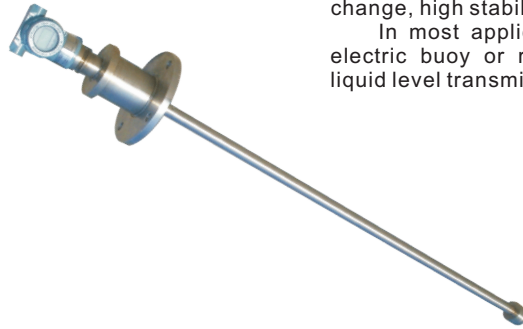

### 主要技术参数

测量范围：300-20000mm（更大量程可定做）

\*精度：液位测量 $\pm 0.1\%$ FS

\*量程比：10:1

\*重复性： $\leq \pm 0.05\%$ FS

\*电源：16~36VDC

\*输出信号：模拟量4-20mADC（HART协议）

\*液晶显示：mmH<sub>2</sub>O, KPa, %

\*最大负载电阻：24VDC供电时

\*密度范围： $100 < \rho < 3000 \text{Kg/m}^3$

\*工作压力：2.5~16MPa

\*介质温度： $-60^\circ\text{C} \sim 280^\circ\text{C}$

\*环境温度： $-40^\circ\text{C} \sim 70^\circ\text{C}$

\*工作条件影响：

供电影响：当电压在规定电压的最小值与最大值之间变化时，输出变化 $\leq \pm 0.02\%$ FS

温度影响： $\leq 0.05\%/10^\circ\text{C}$

\*防护等级：IP67(NEMA 4X)

\*防爆等级：本安型 ExiaIICT4-T6, 隔爆型 ExdIICT4-T6

\*电气接口：1/2-14NPT内螺纹, M20×1.5内螺纹

\*接线盒：铝合金

### Main technical parameters:

Measurement scope: 300-20000mm(customized for larger range)

Accuracy: liquid level measurement $\pm 0.1\%$ FS

Rang ratio: 10:1

Repeatability:  $\leq \pm 0.05\%$ FS

Power supply: 16~36VDC

Output signal: analog 4-20mADC (HART protocol)

Liquid crystal display: mmH<sub>2</sub>O, KPa, %

Maximum load resistor: when 24VDC power supply

Density range:  $100 < \rho < 3000 \text{Kg/m}^3$

Working pressure: 2.5~16MPa

Medium temperature:  $-60^\circ\text{C} \sim 280^\circ\text{C}$

Ambient temperature:  $-40^\circ\text{C} \sim 70^\circ\text{C}$

Influence of working conditions:

Power supply influence: when the voltage changes between the minimum value and the maximum value of the specified voltage, the output changes $\leq \pm 0.02\%$ FS

Temperature influence $\leq 0.05\%/10^\circ\text{C}$

Protection class: IP67(NEMA 4X)

Explosion proof class: intrinsic safety type, explosion proof type.

Electric interface: 1/2-14NPT inner thread, M20×1.5 inner thread

Terminal box: aluminum alloy

联系人：姚经理：13685509377 Email: 115192082@qq.com

**TK6800电动差压式液位变送器型号规格**  
**Model and specification of TK6800 electric differential**

型号 Model	变送器类型 transmitter type
TK6800	电动压差式液位变送器 electric differential pressure liquid level transmitter
代号 Code	压力量程 pressure range
1	插入式 200~300mmH2O inserted type 200~300mmH2O
2	沉入式 1000~20000mmH2O immersion type 1000~20000mmH2O
3	汽包液位式 (选型材料另询) bubble level type (please inquire the selection material separately)
代号 Code	变送器类型 transmitter type
A	基本型 -40~80℃ basic type -40~80℃
B	高温型 -40~280℃ high temperature type -40~280℃
C	防腐型 -40~120℃ corrosion prevention type -40~120℃
代号 Code	安装方式 installation type
N	顶装式 top installation type
H	侧侧外装式 side side external installation type
C	侧底外装式 side bottom external installation type
D	汽包液位型 bubble level type
I	特殊型 (客户提供图纸) special type (drawing provided by the customer)
代号 Code	配套选择 accessory selection
X1	不带连通器 no communicating vessel
X2	配套连通器 (用户提供参数) supporting communicating vessel (parameter provided by the user)
代号 Code	输出信号 output signal
H	4~20mA HART
代号 Code	接液材质 liquid connection material
A	316L
B	316L+特氟龙 316L+Teflon
C	316L+聚四氟乙烯 316L+PTFE
代号 Code	安装法兰 installation flange
A	DN80
B	DN65
C	用户指定 customer designated
代号 Code	工作压力 working pressure
P1	≤6.3MPa
P2	≤16MPa
代号 Code	电气接口 electric interface
A	M20×1.5
B	1/2NPT
代号 Code	显示方式 display method
A	mmH2O
B	KPa
C	%
代号 Code	防爆等级
E5	本安 ia    CT4/CT6 intrinsic safety ia    CT4/CT6
K5	隔爆 d    CT4/CT6 explosion isolation d    CT4/CT6
	出厂量程 L=mm ex-work range L=mm
	探极长度 H=mm probe length H=mm
TK6800	1 B H X2 C A P1 A B E5

联系人: 姚经理: 13685509377 Email: 115192082@qq.com

2016年7月总第10版  
 样本内容相关数据如因印刷和校对的错误, 不再另行通知, 请以订货时的实际数据为准. 我们将在www.tiankang.com上及时提供最新的电子样本