

INNOVATION MAKES EXCELLENT

有 | 跨 | 越 | 才 | 有 | 卓 | 越

电磁流量计



联系人：姚经理：13685509377 Email：115192082@qq.com

企业简介

Brief Introduction

长江宛如一条巨龙奔腾不息，在长江之滨的天长市有这样一颗璀璨的明珠—安徽天康（集团）股份有限公司，在经历了岁月的历练与洗礼后愈发闪耀夺目。

安徽天康（集团）股份有限公司创建于1974年，总部位于“长三角”经济圈核心区域—天长市，是中国民营企业制造业500强企业、中国电子信息百强企业、国家级守合同重信用企业、国家高新技术企业、安徽省依法纳税先进企业、银行资信AAA级企业、中国仪表行业十强企业、中国电线电缆十强企业、安徽省重点骨干企业、“全国五一劳动奖状”获得者等荣誉。

天康集团历经四十年的蓬勃发展，已形成集仪器仪表、光电缆、医疗卫生、锂电池等跨行业、多元化的集团公司，下属子公司达二十余家。旗下产品凭借良好的质量与服务，被广泛应用于石油、电力、化工、通讯、卫生、新能源汽车及储能等行业和领域。

作为皖东经济最具活力与贡献的骨干企业之一，天康集团以“追求卓越，缔造满意”为目标，依托一流的产品、一流的管理、一流的服务，不仅在国内市场中赢得了广泛赞誉；在国际市场中，天康产品远销欧洲、非洲、亚洲等46个国家和地区。

天康集团在发展中逐步形成了独特的品牌文化及着眼全球的经营部局，全力塑造“高科技、高品质、国际化”的品牌形象。始终秉承“有跨越才有卓越”的天康精神，在创建和谐企业的基础上，引进国际先进的构架与模式，组织企业的生产经营管理体系。在积极参与国际化竞争的基础上，不断把握市场发展脉搏，寻求经济战略联盟，与全球伙伴共同发展与进步。如今天康人将全新的投入化为无私的奉献，与世界共同发展，与人类一起进步。

联系人：姚经理：13685509377 Email: 115192082@qq.com



Yangtze River like a dragon Pentium, there is such a shining pearl - Anhui Tiankang (Group) Co., Ltd. in Tianchang City in the Yangtze River foreshore, in after years of experience and baptism increasingly shining brightly.

Anhui Tiankang (Group) Co., Ltd. created in 1974, the headquarters is located in the "Yangtze River Delta" economic circle core area - Tianchang City, is China's private enterprises in the manufacturing industry 500 strong enterprises, China's electronic information hundred enterprises, state-level keep contract re credit enterprise, national new and high technology enterprise, Anhui Province tax law advanced enterprises, bank credit AAA level enterprise, China instrument industry ten strong enterprises, top ten enterprises in the Chinese wire and cable, Anhui province key enterprises, "national labor certificate" get "and other honorary.

After forty years of vigorous development, the group has formed a set of instruments, optical cable, medical and health, lithium batteries, such as cross industry, diversified group companies, subsidiaries of more than twenty. Products with good quality and service, is widely used in oil, electricity, chemicals, communications, health, new energy vehicles and energy storage and other industries and areas.

As one of the backbone enterprises in Anhui east economy the most vitality and contribution, tecon group to "the pursuit of excellence, creating satisfaction" as the goal, relying on the first-class products, first-class management, first-class service, not only in the domestic market won wide acclaim; in the international market, the day Kang products are exported to 46 countries and regions, including Europe, Africa, and Asia.

Tecon group in the developing gradually formed a unique brand culture and focus on global business department bureau, spare no effort to shape the brand image of "high-tech, high-quality, internationalization". Always adhering to the "excellence," the spirit of Tiankang across only, to create the basis for a harmonious enterprise, the introduction of international advanced framework and patterns, organization of production management system. Actively participate in the international competition, and continue to grasp the pulse of the market development, to seek economic and strategic alliances, and global partners to develop and progress. Such as today, the people will be a new investment into the selfless dedication, and the common development of the world, together with the progress of mankind.

联系人：姚经理：13685509377 Email: 115192082@qq.com

目 录

CONTENTS

工作原理 Working principles	1
产品特点 Product features	1
标准技术规格 Standard technology specifications	2
电磁流量计的主要技术参数 Technical parameters of the electromagnetic flowmeter	4
流量计口径、公称压力和流量范围 Caliber, nominal pressure and flow range of flowmeter	7
电磁流量计的瞬时流量列线图 Instantaneous flow nomograms of electromagnetic flowmeter	8
电磁流量计的电极材料选择 Selection of electrode material	9
衬里材料的选择 Selection of lining material	10
防护等级的选择 Selection of protection level	10
电磁流量计的正确安装 Correct installation of electromagnetic flowmeter	10
电磁流量计外形尺寸图 Overall dimension of the electromagnetic flowmeter	14
电磁流量计尺寸表 Dimension table of electromagnetic flowmeter	15
电气接线 Electrical wiring	17
转换器面板结构与按键定义 Structure of converter panel and meaning of keys	18
TK1100系列标准型电磁流量计型号说明 Description of standard type for TK1100 series	21
TK1200系列高精度电磁流量计型号说明 Description of high accuracy type for TK1200 series	23
TK1300系列卫生型电磁流量计型号说明 Description of hygienic type for TK1300 series	25
TK1400系列插入式电磁流量计型号说明 Description of inserted type for TK1400 series	26
TK1500系列电池供电电磁流量计型号说明 Description of battery powered type for TK1500 series	28
TK1600系列电磁(热能)流量计型号说明 Description of electromagnetic (heat energy) type for TK1600 series	30
电极材质防腐选用参考表 Reference table for anti-corrosion of electrode materials	32
常见液体电导率参数表 Parameter table of liquid conductivity	34
组态数据表 Data table of configuration	35

TK1000系列电磁流量计

Electromagnetic flowmeter for TK1000 series

工作原理

法拉第感应定律（指的是当导体通过磁场时会在导体内部产生感应电势）即为电磁流量计测量的基本原理。这种测量原理可应用于具有导电性的流体，该流体流入磁场垂直于流体方向的管道，在流体中感应生成的电势可利用对称布置的两个电极进行测量。信号电压 U_E 与磁感应强度 B ，电极间距 D 以及流体平均速度 v 成正比。由于磁感应强度 B 与电极间距 D 为常量，所以信号电压 U_E 与平均流速 v 成正比。用于计算体积流速的等式表明信号电压 U_E 与体积流量成线性正比。

感应的信号电压被转化为转换器中的分度，模拟以及数字输出信号。

Working principle

Faraday law of electromagnetic induction (It means when the conductor flow through the magnetic field, it can cause induced electromotive force in conductor). It is the measuring principle of electromagnetic flowmeter. This measuring principle can be applied to conductive fluid. The fluid flows into a pipeline which is perpendicular to the direction of the fluid. The electromotive force induced in the flow can use the two symmetrical electrodes to measure. Signal voltage U_E is proportional to magnetic flux density B , electrode spacing D and average velocity of the fluid v . Magnetic flux density B and electrode spacing D are constants, so signal voltage U_E is proportional to average flow velocity of the fluid v . Equation for calculating the volume flow rate means signal voltage U_E is linearly proportional to volume flow.

The induced signal voltage is converted to the indexing of the converter, analog and digital output signals.

电磁流量计示意图
schematic of electromagnetic flowmeter

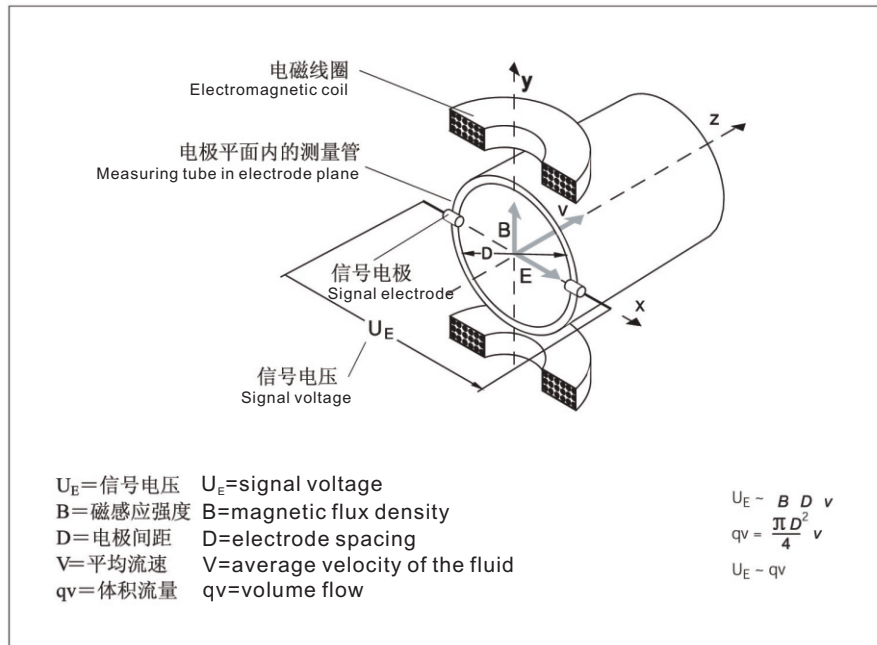

产品特点

采用国际领先的励磁技术，励磁电路简洁，稳定可靠，具备人工智能的性能。

管道内无可动部件，无阻流部件，测量中几乎没有附加压力损失。

测量结果与流速分布、流体压力、温度、密度、粘度等物理参数无关。

在现场可根据用户在线修改量程。

适用于各种导电液体的流量测量，如自来水、污水、泥浆、各类饮料、化学原料、粘稠液体和悬浮物。具有低电导测量功能。

Ex防爆设计，符合国家防爆技术要求，已通过鉴定验收，可应用于各类防爆场所。

Product features

It uses the international leading excitation technology. The excitation circuit is simple, stable and reliable, it has the performance of artificial intelligence.

There are no movable parts and no resisting flow parts in the pipeline.

There is no additional pressure-loss. The measurement results have no relationship to flow velocity distribution, fluid pressure, temperature, density, viscosity and other physical parameters.

It can modify the range online according to the actual need of users.

It can be used to measure the flow of conductive fluid, such as tap water, sewage, mud, all kinds of drinks, chemical materials, viscous liquid and suspended solids. It has low conductivity measurement function.

Ex explosion-proof design meet the requirements of the national explosion-proof technology, it has passed the identification and acceptance, and it can be used in all kinds of explosion-proof places.

高阻快速响应设计，无失真地采集微弱信号和快速反应流量变化，量程比可达 100:1。

采用电容式技术的空、满管检测技术，杜绝误报警的出现。

具备转换器互换的一致性，无须重新输入参数。宽范围电源模式可供选择 (DC: 18V~36V AC: 85V~265V)。

采用出厂保存设置功能，使仪表各参数万无一失。

红外遥控功能以及按键操作，操作更加方便。

提供传感器零点修正以及自动校零功能。

全中文(英文)友好界面，满足各方使用要求。

具备转换器本机自校、自检功能。

具备防雷电保护设计电路。高效抗干扰电路，适用各种恶劣环境。

具有RS485、RS232、Hart、Modbus和

Profibus等数字通讯信号输出。

转换器和传感器具有多种防护等级及安装方式，有适用于潜水安装的IP68等级。

插入式电磁流量计在大管道流量检测中，安装简单，不需断流，现场可带压开孔，具有绝对的安装优势与价格优势。插入式电磁流量的测量只与插入深度有关，故该流量计通用性广，互换性强。一种型号就可适用于各种规格管道的流体测量要求。

Fast response design of high resistance can collect the weak signals without distortion and reflect the change of the flow. The range ratio can reach to 100:1.

It used the empty and full pipe detection of capacitive technology and prevent the false alarm of emergence.

It has the consistency of the converter swap, It's no need to re-enter the parameters.

And it has wide range power type to choose (DC: 18V~36V AC: 85V~265V).

It uses the factory function to save the settings and to ensure that no danger of anything going wrong with the instrument parameters. Infrared remote control function and keys operation let the operation more convenient.

It has the function of sensor zero correction and automatic zero calibration.

Chinese (English) interface can meet different kinds of requirements.

It also has converter self-calibration and self check function.

The circuit has anti lightning protection design. Anti-interference circuit can apply to harsh environment.

It has digital communication signal output, like RS485, RS232, Hart, Modbus and Profibus, etc.

Converters and sensors have a variety of protection levels and installation methods. IP68 level is suitable for diving installation. Inserted electromagnetic flowmeter in large pipe flow measurement has advantages, like simple installation, without interrupting scene and hot tapping, so it has installation advantage and price advantage.

The measurement of the inserted electromagnetic flowmeter is only related to the depth of insertion, so the flowmeter is widely used and has high interchangeability. A kind of type can be applied to a variety of specifications of the pipeline fluid measurement.

标准技术规格

1. 正常工作条件

环境温度: $-30\sim+65^{\circ}\text{C}$;

相对湿度: $5\sim90\%$;

供电电源: 单相交流电源 $85\sim265\text{V}$, $45\sim63\text{Hz}$;

直流电源DC power supply $18\text{VDC}\sim36\text{VDC}$

耗散功率: 小于15W

2. 测量精度

TK1100标准型: $\pm 0.5\%$;

TK1200高精度: $\pm 0.2\%$;

TK1300卫生型: $\pm 0.2\%$, $\pm 0.5\%$;

TK1400插入式: $\pm 1.5\%$;

TK1500电池供电型: $\pm 0.5\%$;

TK1600电磁热能表: $\pm 1.0\%$

Standard technical specifications

1. Normal working conditions

ambient temperature: $-30\sim+65^{\circ}\text{C}$; relative humidity: $5\sim90\%$;

power supply: single phase AC power supply $85\sim265\text{V}$, $45\sim63\text{Hz}$;

DC power supply $18\text{VDC}\sim36\text{VDC}$; dissipation power: less than 15W.

1. Measurement accuracy

TK11 standard type: $\pm 0.5\%$;

TK12 high accuracy type: $\pm 0.2\%$;

TK13 hygienic type: $\pm 0.2\%$, $\pm 0.5\%$;

TK14 Insert type: $\pm 1.5\%$;

TK15 battery powered type: $\pm 0.5\%$;

TK16 electromagnetic heat energy meter type: $\pm 1.0\%$

测量误差
Measurement error

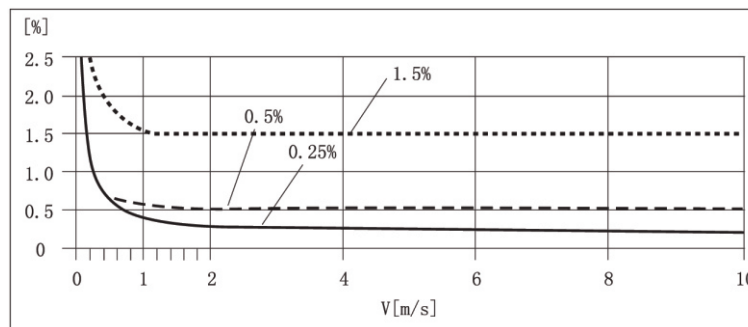

3. 输出变量

3.1 模拟电流输出

负载电阻: $0\sim10\text{mA}$ 时, $0\sim1.5\text{k}\Omega$; $4\sim20\text{mA}$ 时, $0\sim750\Omega$ 。

基本误差: $0.1\%\pm 10\mu\text{A}$ 。

3.2 数字频率输出

频率输出范围: $1\sim5000\text{Hz}$;

输出电气隔离: 光电隔离, 隔离电压: $>1000\text{VDC}$;

频率输出驱动: 场效应管输出, 最高承受电压 36VDC , 最大负载电流 250mA 。

3. Output variable

3.1 Analog current output

Load resistance: $0\sim1.5\text{k}\Omega$ when $0\sim10\text{mA}$; $0\sim750\Omega$ when $4\sim20\text{mA}$.

Basic error: $0.1\%\pm 10\mu\text{A}$ 。

3.2 Digital frequency output

Frequency output range: $1\sim5000\text{Hz}$;

Output electrical isolation: photoelectric isolation, isolation voltage: $>1000\text{VDC}$;

Frequency output driver: field effect transistor output, the maximum withstand voltage is 36VDC , the maximum load current is 250mA 。

3.3 数字脉冲输出

输出脉冲范围：0~100脉冲 / 秒。（高于上限时，会丢失脉冲）；

输出脉冲当量：0.001~1.000m3 /cp;
0.001~1.000 LTR /cp;
0.001~1.000 USG /cp;
0.001~1.000 UKG /cp;

输出脉冲宽度：用户软件设置； 输出电气隔离：光电隔离，隔离电压：>1000VDC； 脉冲输出驱动：场效应管输出，最高承受电压36VDC，最大负载电流250mA。

3.4 报警输出

报警输出接点：ALMH—上限报警；ALML—下限报警；

输出电气隔离：光电隔离，隔离电压>1000VDC；
报警输出驱动：达林顿管输出，最高承受电压36VDC，最大负载电流250mA

3.5 数字通讯接口及通讯协议

MODBUS接口：RTU格式，物理接口RS-485，电气隔离1000V；

HART接口：支持标准HART协议，配置HART手持器，可在线显示测量值，并可修改仪表参数；

3.3 Digital pulse output

Output pulse range: 0 ~ 100 pulse per second (higher than the upper limit, the pulse will be lost);

Output pulse equivalent: 0.001~1.000m3 /cp;
0.001~1.000 LTR /cp;
0.001~1.000 USG /cp;
0.001~1.000 UKG /cp;

Output pulse width: user software settings; output electrical isolation: photoelectric isolation, isolation voltage: >1000VDC; pulse output driver: field effect transistor output, the maximum withstand voltage is 36VDC, the maximum load current is 250mA.

3.4 Alarm output

Alarm output contact: ALMH - limit alarm; ALML - lower alarm; output electrical isolation: photoelectric isolation, isolation voltage:>1000VDC;
Alarm output driver: Darlington output, maximum withstand voltage is 36VDC, the maximum load current is 250mA.

3.5 Digital communication interface and communication protocol

Alarm output contact: ALMH - limit alarm; ALML - lower alarm; output electrical isolation: photoelectric isolation, isolation voltage:>1000VDC;

HART interface: it support the standard HART protocol, configure the HART hand held device, it can display the measured value online, and can modify the instrument parameters;

联系人：姚经理：13685509377 Email: 115192082@qq.com

电磁流量计的主要技术参数

Technical parameters of the electromagnetic flowmeter



型号 Model	TK1100 标准型系列 TK1100 standard series	TK1200 高精度系列 TK1200 high accuracy series
口径 Caliber	DN3-DN2200	DN10-DN300
精度 Accuracy	0.5%	0.2%, 0.3%
安装方式 Installation method	夹持, 法兰 Hold, flange	夹持, 法兰 Hold, flange
重复性 Repeatability	0.1%	0.06%, 0.1%
测量范围 Measuring range	0-12m/s(流量单位可改变) 0-12m/s(flow unit can be changed)	0-12m/s(流量单位可改变) 0-12m/s(flow unit can be changed)
连接法兰 Connecting flange	GB/T9119-2000 或其他选择 GB/T9119-2000 or any other choice	GB/T9119-2000 或其他选择 GB/T9119-2000 or any other choice
压力 Pressure	4.0MPa~0.25 Mpa (按口径分classify by caliber)	4.0MPa~0.25 Mpa (按口径分classify by caliber)
衬里材料 Lining material	PO,PTFE,PFA(耐负压negative pressure resistance), 橡胶rubber, 聚氨酯polyurethane)	PO,PTFE,PFA(耐负压negative pressure resistance), 橡胶rubber, 聚氨酯polyurethane)
电极材料 Electrode material	316L,HC,HB, 钛, 钽, 铂金 316L,HC,HB, titanium, tantalum, platinum	316L,HC,HB, 钛, 钽, 铂金 316L,HC,HB, titanium, tantalum, platinum
电极形式 Electrode form	标准,(刮刀,可更换 DN>350) Standard,(scraper,it can be replaced by DN>350)	标准,(刮刀,可更换 DN>350) Standard,(scraper,it can be replaced by DN>350)
传感器防护等级 Protection level of sensor	IP65, IP67, IP68	IP65, IP67, IP68
电导率 Conductivity	> 5 μ S/cm (水water> 20 μ S/cm)	> 2 μ S/cm (水water> 20 μ S/cm)
介质最高温度 Maximum temperature of medium	一体型 \leq 90 $^{\circ}$ C, 分体型 \leq 160 $^{\circ}$ C (橡胶、PO \leq 70 $^{\circ}$ C) Integrated type \leq 90 $^{\circ}$ C,split type \leq 160 $^{\circ}$ C (rubber, PO \leq 70 $^{\circ}$ C)	一体型 \leq 90 $^{\circ}$ C, 分体型 \leq 160 $^{\circ}$ C (橡胶、PO \leq 70 $^{\circ}$ C) Integrated type \leq 90 $^{\circ}$ C,split type \leq 160 $^{\circ}$ C (rubber)
环境最高温度 Ambient maximum temperature	-30 $^{\circ}$ C ~+65 $^{\circ}$ C	-30 $^{\circ}$ C ~+65 $^{\circ}$ C
转换器安装形式 Converter installation mode	一体, 分体 Integrated,split	一体, 分体 Integrated,split
输出信号 Output signal	4-20mA 电流信号, 频率 / 脉冲输出 4-20mA current signal, frequency / pulse output	4-20mA 电流信号, 频率 / 脉冲输出 4-20mA current signal, frequency / pulse output
电源 Power supply	AC:85V~265V,DC:18V~36V	AC:85V~265V,DC:18V~36V
自诊断 Self diagnosis	有yes	有yes
空管置零 Zero setting of empty pipe	有yes	有yes
通讯 Communication	RS485/Modbus, HART, PROFIBUS	RS485/Modbus, HART, PROFIBUS
防爆 Explosion-proof	非防爆 / 隔爆 No explosion proof/explosion proof	非防爆 / 隔爆 No explosion proof/explosion proof
语言 Language	中文, 英语Chinese, English	中文, 英语Chinese, English
产品标准 Product standards	JB/T 9248-1999	JB/T 9248-1999



型号 Model	TK1300 卫生型系列 TK1300 hygienic series	TK1500 电池供电系列 TK1500 battery powered series
口径 Caliber	DN3-DN150	DN10-DN1200
精度 Accuracy	0.2%, 0.5%	0.5%
安装方式 Installation method	螺纹, 卡箍 Thread, clamp	夹持, 法兰 Hold, flange
重复性 Repeatability	0.06%, 0.1%	0.15%
测量范围 Measuring range	0-12m/s(流量单位可改变) 0-12m/s(flow unit can be changed)	0-10m/s(流量单位可改变) 0-10m/s(flow unit can be changed)
连接法兰 Connecting flange		GB/T9119-2000 或其他选择 GB/T9119-2000 or any other choice
压力 Pressure	最高4.0MPa The highest 4.0MPa	4.0MPa~0.6 Mpa (按口径分类) classify by caliber)
衬里材料 Lining material	PFA (耐负压) PFA(negative pressure resistance)	PO,PTFE,PFA (耐负压negative pressure resistance) , 橡胶rubber, 聚氨酯polyurethane)
电极材料 Electrode material	316L,HC,HB, 钛, 钽, 铂金 316L,HC,HB, titanium, tantalum, platinum	316L,HC,HB, 钛, 钽, 铂金 316L,HC,HB, titanium, tantalum, platinum
电极形式 Electrode form	标准 Standard	标准, (刮刀, 可更换 DN>350) Standard,(scraper,it can be replaced by DN>350)
传感器防护等级 Protection level of sensor	IP65, IP67, IP68	IP65, IP67, IP68
电导率 Conductivity	> 2μS/cm (水 > 20μS/cm) > 2μS/cm (water > 20μS/cm)	> 5μS/cm (水 > 20μS/cm) > 5μS/cm (water > 20μS/cm)
介质最高温度 Maximum temperature of medium	一体型 ≤ 90°C, 分体型 ≤ 160°C Integrated type ≤ 90°C, split type ≤ 160°C	一体型 ≤ 90°C, 分体型 ≤ 160°C (橡胶, PO ≤ 70°C) Lntegrated type ≤ 90°C, split type ≤ 160°C (rubber, PO ≤ 70°C)
环境最高温度 Ambient maximum temperature	-30°C ~+65°C	-30°C ~+65°C
转换器安装形式 Converter installation mode	一体, 分体 Integrated, split	一体, 分体 Lntegrated, split
输出信号 Output signal	4-20mA 电流信号, 频率 / 脉冲输出 4-20mA current signal, frequency / pulse output	频率0-5kHz Frequency 0-5kHz
电源 Power supply	AC:85V~265V,DC:18V~36V	3.6V
自诊断 Self diagnosis	有Yes	有Yes
空管置零 Zero setting of empty pipe	有Yes	有Yes
通讯 Communication	RS485/Modbus, HART, PROFIBUS	RS485/Modbus, GPRS
防爆 Explosion-proof	非防爆 / 隔爆 No explosion proof/explosion proof	
语言 Language	中文, 英语Chinese, English	中文, 英语Chinese, English
产品标准 Product standards		JB/T 9248-1999



型号 Model	TK1400 插入式系列 TK1400 inserted type series	TK1600 电磁热能表系列 TK1600 electromagnetic heat meter series
口径 Caliber	DN200-DN3000	DN15-DN1200
精度 Accuracy	1.5%;2.5%	1.0%, 2.0%, 2.5%
安装方式 Installation method	法兰, 螺纹, 在线 Flange, thread, on-line	夹持, 法兰, 螺纹 Hold, flange, thread
重复性 Repeatability	0.5%	0.3%;0.5%
测量范围 Measuring range	0-10m/s(流量单位可改变) 0-10m/s(flow unit can be changed)	0-12m/s(流量单位可改变) 0-12m/s(flow unit can be changed)
连接法兰 Connecting flange	GB/T9119-2000 或其他选择 GB/T9119-2000 or any other choice	GB/T9119-2000 或其他选择 GB/T9119-2000 or any other choice
压力 Pressure	1.6 MPa	4.0MPa-0.6 Mpa (按口径分classify by caliber)
衬里材料 Lining material	POM,PTFE,PFA	PO,PTFE,PFA(耐负压negative pressure resistance), 橡胶rubber, 聚氨酯polyurethane)
电极材料 Electrode material	316L,HC,HB, 钛, 钽, 铂金 316L,HC,HB, titanium, tantalum, platinum	316L,HC,HB, 钛, 钽, 铂金 316L,HC,HB, titanium, tantalum, platinum
电极形式 Electrode form	标准 Standard	标准 Standard
传感器防护等级 Protection level of sensor	IP65, IP67, IP68	IP65, IP67, IP68
电导率 Conductivity	> 5 μ S/cm (水 > 20 μ S/cm) > 5 μ S/cm (water > 20 μ S/cm)	> 5 μ S/cm (水 > 20 μ S/cm) > 5 μ S/cm (water > 20 μ S/cm)
介质最高温度 Maximum temperature of medium	一体型 \leq 90 $^{\circ}$ C, 分体型 \leq 130 $^{\circ}$ C) (POM \leq 100 $^{\circ}$ C) Integrated type \leq 90 $^{\circ}$ C, split type \leq 130 $^{\circ}$ C (POM \leq 100 $^{\circ}$ C)	一体型 \leq 90 $^{\circ}$ C, 分体型 \leq 160 $^{\circ}$ C (橡胶, PO \leq 70 $^{\circ}$ C) Integrated type \leq 90 $^{\circ}$ C, Split type \leq 160 $^{\circ}$ C (rubber, POM \leq 70 $^{\circ}$ C)
环境最高温度 Ambient maximum temperature	-30 $^{\circ}$ C ~+65 $^{\circ}$ C	-30 $^{\circ}$ C ~+65 $^{\circ}$ C
转换器安装形式 Converter installation mode	一体, 分体 Integrated, split	一体, 分体 Integrated, split
输出信号 Output signal	4-20mA 电流信号, 频率 / 脉冲输出 4-20mA current signal, frequency / pulse output	4-20mA 电流信号, 频率 / 脉冲输出 4-20mA current signal, frequency / pulse output
电源 Power supply	AC:85V~265V,DC:18V~36V	AC:85V~265V,DC:18V~36V
自诊断 Self diagnosis	有Yes	有yes
空管置零 Zero setting of empty pipe	有Yes	有yes
通讯 Communication	RS485/Modbus, HART, PROFIBUS	RS485/Modbus, HART, PROFIBUS
防爆 Explosion-proof	非防爆 / 隔爆 No explosion proof/explosion proof	非防爆 / 隔爆 No explosion proof/explosion proof
语言 Language	中文, 英语Chinese, English	中文, 英语Chinese, English
产品标准 Product standards		参照 JB/T 9248-1999 Refer to 9248-1999 JB/T

流量计口径、公称压力和流量范围

Caliber, nominal pressure and flow range of flowmete

瞬时体积流量是流速和传感器口径的函数。瞬时流量列线图表明每一口径流量计可以测量的流量范围，同时给出适合测量某给定流量的几种传感器口径规格。

The instantaneous volume flow rate is a function of velocity and the sensor diameter. Instantaneous flow nomograms shows that the flow range that each caliber flowmeter can measure, and give several sensor caliber specifications which is suitable for a given flow.

口径 DN	压力 MPA	最小流量范围 Minimum flow range 流速0-0.5m/s flow0-0.5m/s	最大流量范围 Maximum flow range 流速0-10m/s flow0-0.5m/s
3	4.0	0-0.2L/min	0-4L/min
4	4.0	0-0.4L/min	0-8L/min
6	4.0	0-1.0L/min	0-20L/min
8	4.0	0-1.5L/min	0-30L/min
10	4.0	0-2.25L/min	0-45L/min
15	4.0	0-5L/min	0-100L/min
20	4.0	0-7.5L/min	0-150L/min
25	4.0	0-10L/min	0-200L/min
32	4.0	0-20L/min	0-400L/min
40	4.0	0-30L/min	0-600L/min
50	4.0	0-3m ³ /h	0-60m ³ /h
65	4.0	0-6m ³ /h	0-120m ³ /h
80	4.0	0-9m ³ /h	0-180m ³ /h
100	1.6	0-12m ³ /h	0-240m ³ /h
125	1.6	0-21m ³ /h	0-420m ³ /h
150	1.6	0-30m ³ /h	0-600m ³ /h
200	1.6	0-54m ³ /h	0-1080m ³ /h
250	1.6	0-90m ³ /h	0-1800m ³ /h
300	1.0	0-120m ³ /h	0-2400m ³ /h
350	1.0	0-165m ³ /h	0-3300m ³ /h
400	1.0	0-225m ³ /h	0-4500m ³ /h
500	1.0	0-330m ³ /h	0-6600m ³ /h
600	1.0	0-480m ³ /h	0-9600m ³ /h
700	1.0	0-660m ³ /h	0-13200m ³ /h
800	1.0	0-900m ³ /h	0-18000m ³ /h
900	1.0	0-1200m ³ /h	0-24000m ³ /h
1000	1.0	0-1350m ³ /h	0-27000m ³ /h
1200	0.6	0-2100m ³ /h	0-42000m ³ /h
1400	0.6	0-2700m ³ /h	0-54000m ³ /h
1600	0.6	0-3600m ³ /h	0-72000m ³ /h
1800	0.6	0-4500m ³ /h	0-90000m ³ /h
2000	0.6	0-5700m ³ /h	0-114000m ³ /h

电磁流量计的瞬时流量列线图

The instantaneous flow diagrams of electromagnetic flowmeter

例：瞬时流量=7m³/h（最大值即量程的上限）。流速介于0.5-10m/s之间时，适用的传感器口径（DN20-DN65）。

Example: instantaneous flow =7m³/h (maximum value means the upper limit of the measuring range). When the flow rate is between 0.5-10m/s, the sensor diameter (DN20-DN65) is suitable.

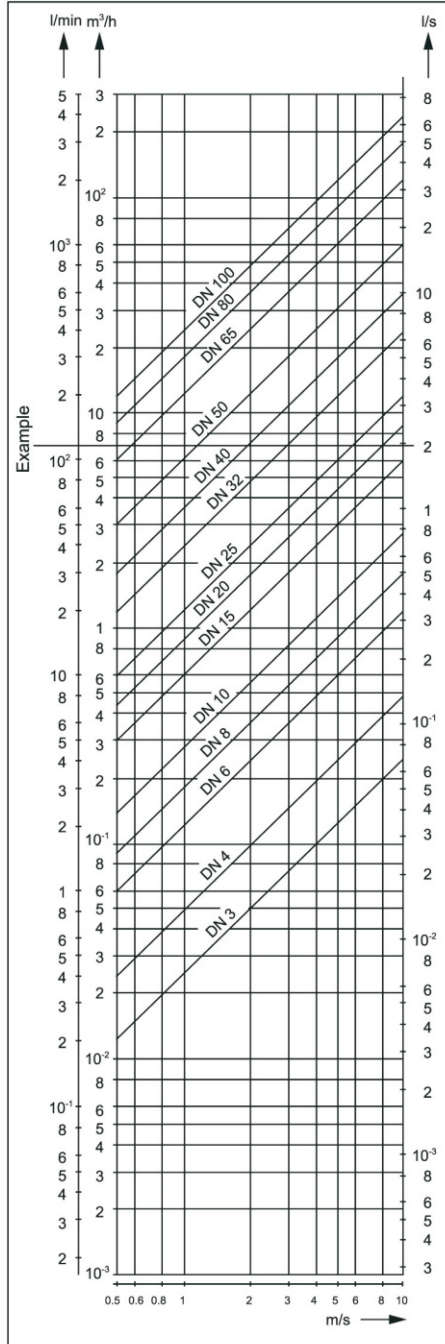

DN3-DN100

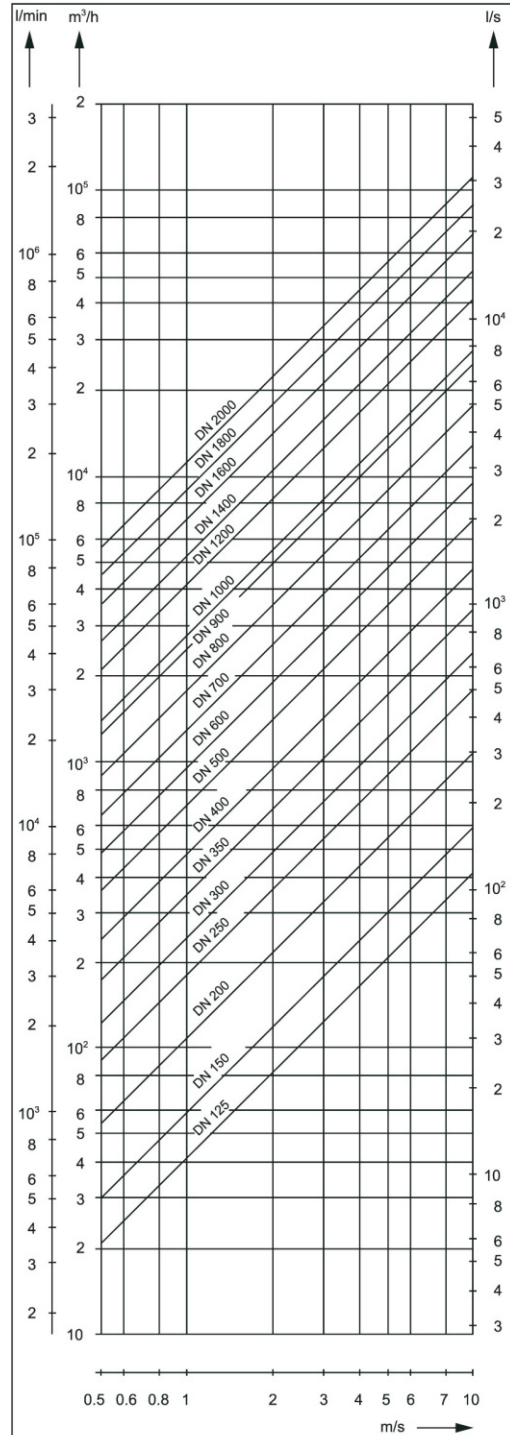

DN125-DN2000

电磁流量计的电极材料选择

Selection of electrode materials for electromagnetic flowmeter

根据被测流体的腐蚀性来选择电极的材料

The material of the electrode is selected according to the corrosive of the tested fluid.

材料 Material Science	耐腐蚀性 Material Science
316L	适用：1. 生活用水，工业用水，原水井水，城市用水 Application: domestic water, industrial water, raw water well water, urban water
	2. 稀酸，稀碱等弱腐蚀性，碱盐液 Weak corrosion such as dilute acid and dilute alkali, alkali salt solution
哈氏合金B Hastelloy alloy B	适用：1. 盐酸(浓度小于10%)等非氧化性酸 Application: non oxidative acid, like hydrochloric acid (concentration is less than 10%), etc
	2. 氢氧化钠(浓度小于50%)一切浓度的氢氧化铵碱溶液 Sodium hydroxide (concentration of less than 50%) ammonium hydroxide solution of all concentrations
	3. 磷酸，有机酸 Phosphoric acid, organic acid
	不适用：硝酸 Not applicable: nitric acid
哈氏合金C Hastelloy alloy C	适用：1. 混合酸如铬酸与硫酸的混合溶液 Application: Mixed acid such as the mixed solution of chromic acid and sulfuric acid
	2. 氧化性盐类如Fe ⁺⁺⁺ 、Cu ⁺⁺ 、海水 Oxidizing salts such as Fe ⁺⁺⁺ 、Cu ⁺⁺ , sea water
	不适用：盐酸 Not applicable: hydrochloric acid
钛(Ti) Titanium (Ti)	适用：1. 盐。如(1)氯化物(氯化物 / 镁 / 铝 / 钙 / 铵 / 铁等) Application: salt, such as chloride (chloride / magnesium / aluminum / calcium / ammonium / iron, etc.)
	(2) 钠盐，铵盐，次氯酸盐，海水 Sodium salt, ammonium salt, hypochlorite, sea water
	2. 浓度小于50%氢氧化钾，氢氧化铵，氢氧化钡碱溶液 Potassium hydroxide (concentration of less than 50%), ammonium hydroxide, alkali solution of barium hydroxide
	不适用：盐酸，硫酸，磷酸，氢氟酸等还原性酸 Not applicable: reductive acid, such as hydrochloric acid, sulfuric acid, phosphoric acid, hydrofluoric acid, etc.
钽(ta) Tantalum	适用：1. 盐酸(浓度小于40%)，稀硫酸和浓硫酸(不包括发烟硫酸) Application: salt, such as chloride (chloride / magnesium / aluminum / calcium / ammonium / iron, etc.)
	2. 二氧化氯，氯化铁，次氯酸，氰化钠，乙酸铅等 Chlorine dioxide, ferric chloride, sodium hypochlorite, sodium cyanide, lead acetate etc.
	3. 硝酸(包括发烟硝酸)等氧化性酸，温度低于80℃的王水 Oxidizing acid such as nitrate (including fuming nitric acid), aqua regia lower than 80℃
	不适用：碱，氢氟酸 Not applicable: alkali, hydrofluoric acid
铂(Pt) Platinum	适用：几乎所有酸，碱，盐溶液(包括发烟硫酸、发烟硝酸) Application: almost all acid, alkali, salt solution (including smoke sulfuric acid, smoke nitric acid)
	不适用：王水，铵盐 Not applicable: aqua regia, ammonium salt
碳化钨 Tungsten Carbide	适用：纸浆，污水，能抗固体颗粒干扰 Application: pulp, sewage, can resist the solid particle interference
	不适用：无机酸，有机酸，氯化物 Not applicable: inorganic acid, organic acid, chloride

衬里材料的选择 Selection of lining material

应根据被测介质的腐蚀性、磨损性及温度来选择。硬/软橡胶可耐一般的弱酸、碱的腐蚀，耐温65℃，软橡胶有耐磨性，聚四氟乙烯(PTFE)几乎能耐除热磷酸以外的强酸、碱腐蚀，介质温度可达130℃，但不可耐磨损。聚胺脂橡胶有较好的耐磨损，但不耐酸、碱腐蚀，耐温度性也较差，介质温度小于65℃。It should be chosen by the corrosive property, abrasability and temperature of the measured medium. Hard / soft rubber can resist general corrosion of weak acid, alkali, high temperature of 65℃. Soft rubber has wear resistance. Polytetrafluoroethylene(PTFE) can resist the corrosion of alkali, strong acid except hot phosphoric acid. Medium temperature can be up 130℃, but can't resist abrasion. Urethane rubber has good abrasiveness, but can't resist the corrosion of acid and alkali, temperature resistance is also poor. Medium temperature is less than 65℃.

衬里材料 Lining material	主要功能 Major function	适用范围 Scope of application
硬橡胶 Hard rubber	<ol style="list-style-type: none"> 1. 可耐常温下的盐酸、醋酸、草酸、氨水、磷酸及50%的硫酸、氢氧化钠、氢氧化钾。 2. 忌强氧化剂。 <ol style="list-style-type: none"> 1. It can resist hydrochloric acid, acetic acid, oxalic acid, ammonia, phosphoric acid and 50% sulfuric acid, sodium hydroxide, potassium hydroxide under normal temperature. 2. avoid strong oxidizing agent. 	<ol style="list-style-type: none"> 1. 低于70℃ 2. 一般的酸、碱、盐溶液 <ol style="list-style-type: none"> 1. below 70 2. general acid, alkali, salt solution
软橡胶 Soft rubber	<ol style="list-style-type: none"> 1. 有较好的弹性，耐磨性能较好。 2. 耐一般的低浓度酸、碱，盐介质的腐蚀，不耐氧化性介质的腐蚀。 <ol style="list-style-type: none"> 1. It has better flexibility and better wear resistance 2. It can resist corrosion of low concentration acid, alkali, salt medium. But it can not resist the corrosion of oxidizing medium 	<ol style="list-style-type: none"> 1. 低于70℃ 2. 测一般水、污水、泥浆、矿浆 <ol style="list-style-type: none"> 1. below 70 2. It can measure water, sewage, slurry, pulp
聚四氟乙烯 Polytetrafluoroethylene (PTFE) 改性聚四氟乙烯 Modified Polytetrafluoroethylene(PFA)	<ol style="list-style-type: none"> 1. 塑料中化学性能最稳定的一种材料，能耐沸腾的盐酸、硫酸、硝酸和王水。也能耐浓碱和各种有机溶剂。 2. 耐磨性和粘接性差 <ol style="list-style-type: none"> 1. A material with the most stable chemical properties in plastic. It can resist the boiling hydrochloric acid, boiling hydrochloric acid, sulfuric acid, nitric acid, aqua regia, concentrated alkali and various organic solvents. 2. Poor wear resistance and poor adhesion 	<ol style="list-style-type: none"> 1. -40℃~+130℃ (PTFE) -40℃~+160℃ (PFA) 2. 酸、碱等强腐蚀介质 3. 卫生的类介质 <ol style="list-style-type: none"> 1. -40℃~+130℃ (PTFE) -40℃~+160℃ (PFA) 2. strong corrosive medium, such as acid, alkali 3. hygienic medium
PO	<ol style="list-style-type: none"> 1. 可耐常温下的盐酸、醋酸、草酸、氨水、磷酸及硫酸、氢氧化钠、氢氧化钾。 2. 能耐浓碱和各种有机溶剂。 <ol style="list-style-type: none"> 1. It can resist hydrochloric acid, acetic acid, oxalic acid, ammonia, phosphoric acid and sulfuric acid, sodium hydroxide, potassium hydroxide under normal temperature 2. It can resist concentrated alkali and various organic solvents 	<ol style="list-style-type: none"> 1. 低于70℃ 2. 一般的酸、碱、盐溶液 3. 一般水、污水、泥浆、矿浆 <ol style="list-style-type: none"> 1. below 70℃ 2. general acid, alkali, salt solution 3. general water, sewage, slurry, pulp

防护等级的选择

按照国际GB/T4208-1993关于外壳防护等级可分为：IP65为防喷水型，即可允许水龙头从任何方向对仪表喷水，喷水压力为30kPa，出水量为12.5升/分，喷水离仪表距离3米。IP67为防浸水型，即仪表可短时间全部浸入水中，试验时最高点应在水下至少150cm，持续时间至少为30分钟。IP68为潜水型，应能长期在水中工作，其浸入的最大深度由制造厂与用户协商。防护等级选用原则应根据以上要求及仪表实际的条件选定。若仪表在地面以下的，经常受水淹的，宜选用IP68；若仪表在地面上的，可选用IP65。

Selection of protection level

According to the international GB/T4208-1993 for the shell protection level, it can be divided into: anti water spray type-IP65, it allows the faucet to water from any direction of the instrument, the water spray pressure is 30kPa, the water volume is 12.5 liters / min, water spray from the meter distance is 3 meters; Water immersion proof type-IP67, Instruments can be immersed in water for a short time. The highest point should be at least 150cm in the water when it is tested, and it should last for at least 30 minutes; Diving type-IP68, it can work in the water for a long time. The maximum depth of immersion should be negotiated with the manufacturer. The selection principle of the protection level should be selected by the above requirements and the actual conditions of the instrument. If the instrument is below the ground, and it is often flooded, you can choose IP68; if the instrument is on the ground, you can choose IP65.

电磁流量计的正确安装

1. 安装场所的选择

1. 选择测量管内不会出现负压的场所；
2. 避免安装在电机、变压器强电设备附近，以免引起电气干扰；
3. 避免安装位置周围有强腐蚀性气体的场所；
4. 测量混合相流体时，避免引起相分离的场所；
5. 环境温度一般在-25℃~60℃范围内，尽可能避免阳光直射；
6. 安装在无振动或选择振动小的场合，如果振动过大，应该在传感器前后的管道上加固定支撑；
7. 环境相对湿度应该在5%-90%范围内；
8. 避免安装在能被雨水直淋或者浸没的场所；

Correct installation of electromagnetic flowmeter

1. Selection of installation site:

1. Choose a place where negative pressure will not appear in the measuring tube;
2. Avoid installing in the motor place, near the transformer in electrical equipment place, so as not to cause electrical interference;
3. Choose a place to avoid strong corrosive gas around the installation position.
4. When measuring mixed phase fluid, we should choose a place to avoid causing phase separation;
5. Ambient temperature is generally in the range of -25℃ ~ 60℃, and it should avoid the direct sunlight.
6. Installed in a place without vibration or a place with small vibration. If the vibration is too large, it should be fixed a support in front of the sensor and behind the sensor.
7. Relative humidity of environment should be in the range of 5%-90%
8. Avoid installing in the place where the rain can be directly poured or immersed;

2. 对直管段长度的要求 (D为流量计的内径)

电磁流量计对前后直管段的要求比较低,一般对于90°弯头, T形三通、异径、全开阀门等流动阻力件, 离电磁流量计的电极轴中线(不是传感器的端面)应该有5D的直管段; 对于不同开度的阀门(比如可调开度的阀门), 则上游侧的直管段长度需要10D。一般传感器下游的直管段只需要3D就可以满足要求。

1.Requirements for length of straight pipe (D is the inner diameter of the flowmeter.)

Electromagnetic flowmeter has lower requirement for the straight pipeline. For 90° elbow, flow resistance parts, like T-type three links, different diameter, fully open valve, the center line of the electrode for the electromagnetic flowmeter (not the end of sensor) should have 5D straight pipe. For different open degrees of the valve (such as adjustable open valve), the upstream side of the straight pipe length needs 10D. the side of the straight pipe length only needs 3D.

如下图所示 Shown as the following figure:

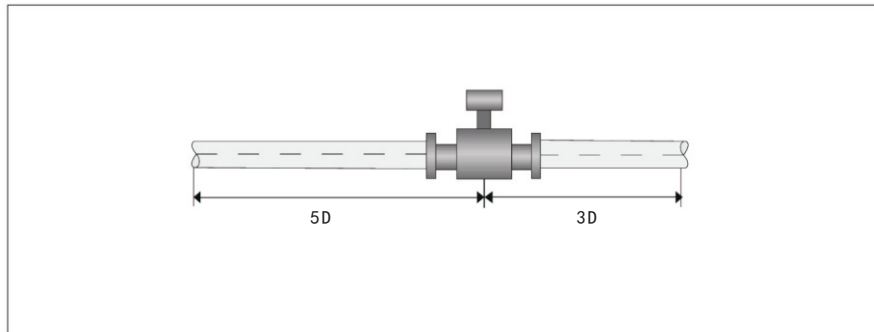

测量不同介质的混合液体时, 混合点与流量计之间的距离至少要大于 30D, 如下图所示:
When measure the mixed liquid of different medium, the distance between the mixing point and the flow meter must be at least more than 30D, shown as the following figure:

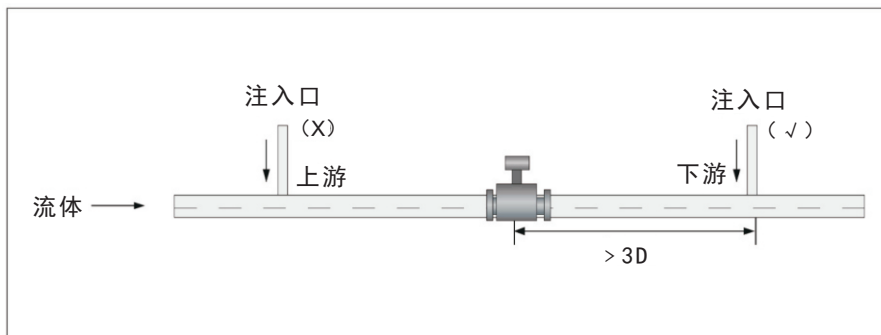

3. 安装位置和流动方向

电磁流量计可以水平、垂直和倾斜安装在管道上:
在水平安装时, 电磁流量计的电极轴必须水平, 防止由于流体所夹带的气泡而产生电极短时间的绝缘, 也可以防止电极被流体中的沉积物覆盖。不应该将传感器安装在最高位置处, 以免有气体聚集。

3.Installation position and flow direction:

The electromagnetic flowmeter can be installed on the pipe in horizontal, vertical and inclined way:

When it is installed in horizontal way, The electrode shaft of the electromagnetic flowmeter must be horizontal. It can prevent electrode insulation for a short time because of bubbles carried by fluid. The electrode can also be prevented from being covered by the sediment in the fluid. The sensor should not be installed at the highest position, so as to avoid the accumulation of gas.

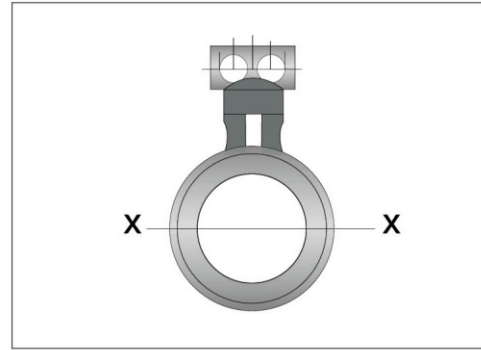
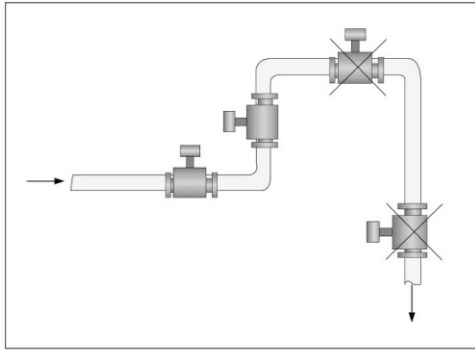

垂直安装时，应该使流动方向向上，这样可以使无流量或者流量很小时，流体中夹带的较重固体颗粒下沉，而轻的脂肪类物质上升离开电磁流量计的传感器电极区，在测量泥浆、矿浆等液固两相介质时避免固相沉淀和传感器衬里不均匀摩擦。如图所示。传感器的测量管道必须充满流体，必须有一定的背压。为防止出现负压(损坏衬里)，电磁流量计不应该安装在泵的进口，而应该安装在泵的出口；在倾斜安装时，必须安装在上升管道；在开口排放的管道安装时，必须安装在管道的较低处。

When it is installed in vertical way. The flow direction should be upward., in this case ,when there is no flow or the flow is very small, the sinking of heavier solid particles entrained in fluid, The light of the fat mass rises away from the sensor electrode area of the electromagnetic flowmeter, In the measurement of liquid-solid two-phase medium, like slurry and pulp, it can avoid solid precipitation and uneven friction of sensor lining. shown as the following figure. Measuring pipe of sensor must be full of fluid and a certain back pressure. In order to prevent negative pressure (damage to the lining). Electromagnetic flowmeters should not be installed in the pump inlet, it should be installed in the pump outlet; When it is installed in inclined way, it must be installed in the rising pipe; When it is installed in open discharge pipe , it must be installed in the lower parts of the pipe.

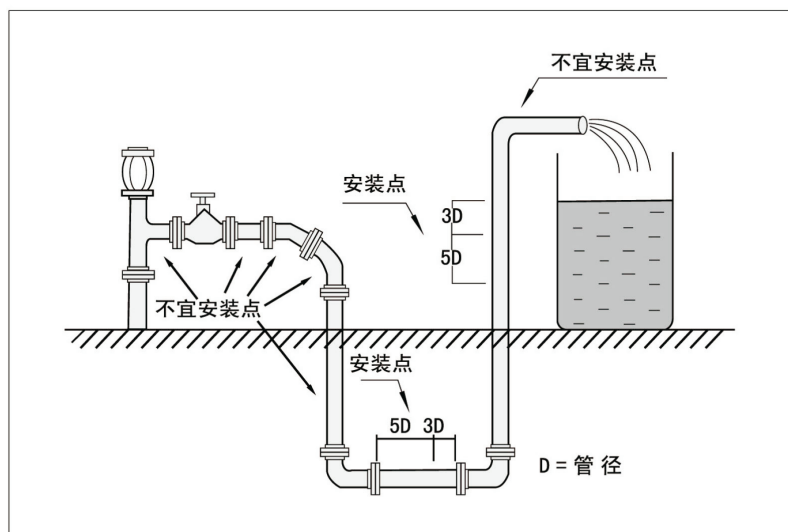
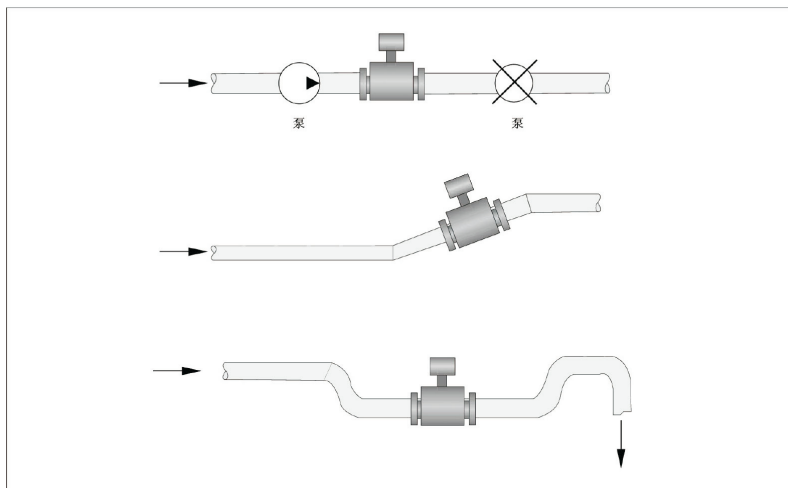

应在传感器的下游安装控制阀和切断阀，而不应该安装在传感器上游
Control valves and cut off valve should be installed in downstream of the sensor, not in upstream of the sensor

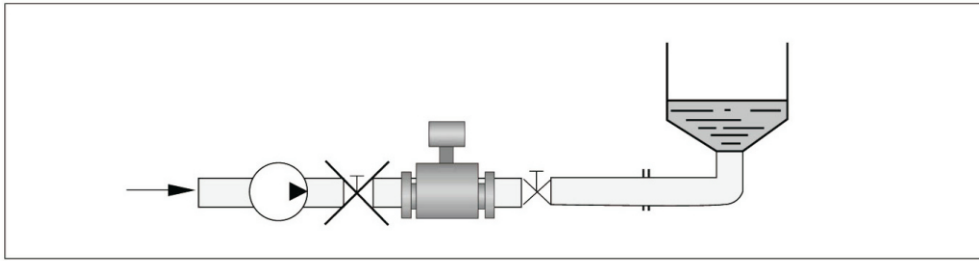

在测量井内安装流量计的方法
Method for installing flow meter in measuring well

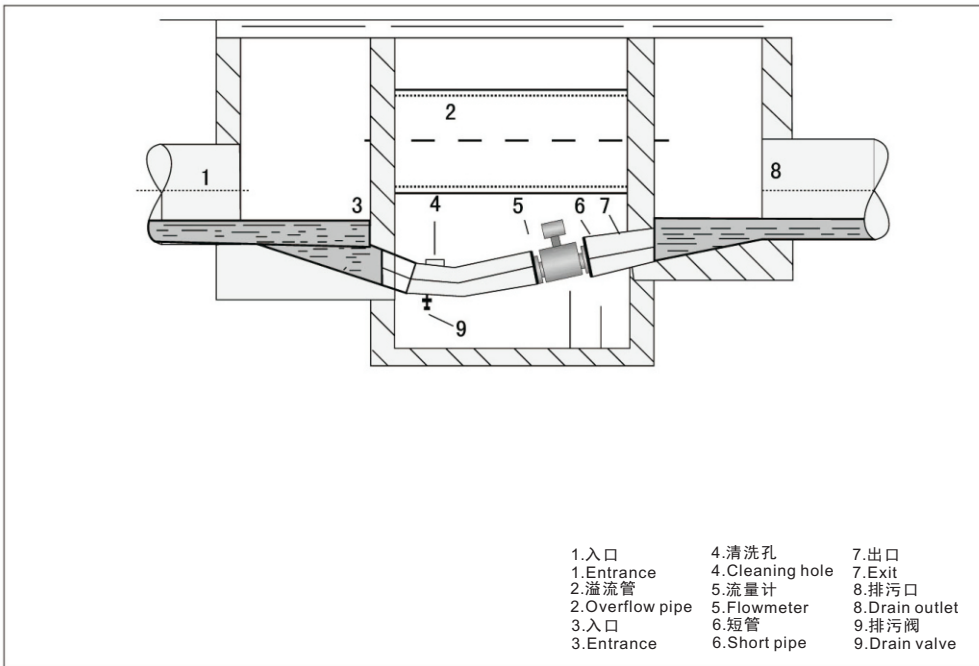

4. 插入式电磁流量计安装图

4. Installation diagram of inserted electromagnetic flowmeter

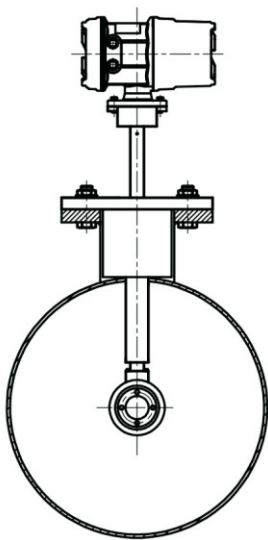

标准型法兰固定插入式电磁流量计
Electromagnetic flowmeter of standard flange fixed inserted type

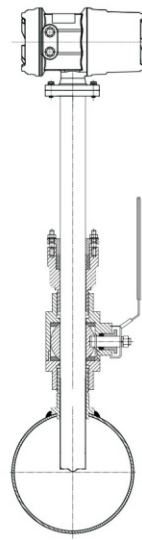

标准型在线插拔式电磁流量计
He electromagnetic flowmeter of standard online plug-unplug type

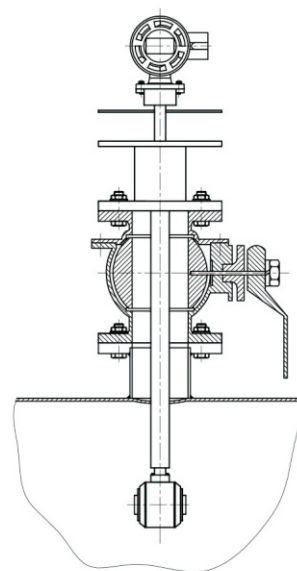

现场管道上开取DN100/DN500口径的孔，再焊接
 口径DN100/DN500的管子和DN100 PN1.6MPa/DN50
 PN1.6MPa法兰或螺 纹底座。将标准型法兰固定插入
 式电磁流量计安装在法兰上。

在标准型法兰固定插入式电磁流量计安装法兰的
 基础上，增加了全通DN100/DN500的球阀。用户可在
 不切断介质的情况下，将 标准型在线插拔式电磁流
 量计抽至最高点，关闭球阀，取出流量计。

Open a hole of DN100/DN500 diameter on the pipeline, weld the pipe
 of DN100/DN500 diameter and PN1.6MPa/DN50 PN1.6MPa DN100
 flange or screw base, then install the electromagnetic flowmeter of
 standard flange fixed inserted type on the flange.

On the basis of the installation flange of the standard flange fixed
 inserted type electromagnetic flowmeter, it also add the ball valve of
 all passed DN100/DN500 . The user can pump the electromagnetic
 flowmeter of standard online plug-unplug type to the highest point
 without cutting off the medium, close ball valve and take out the
 flowmeter

电磁流量计外形尺寸图 Overall dimension of the electromagnetic flowmeter

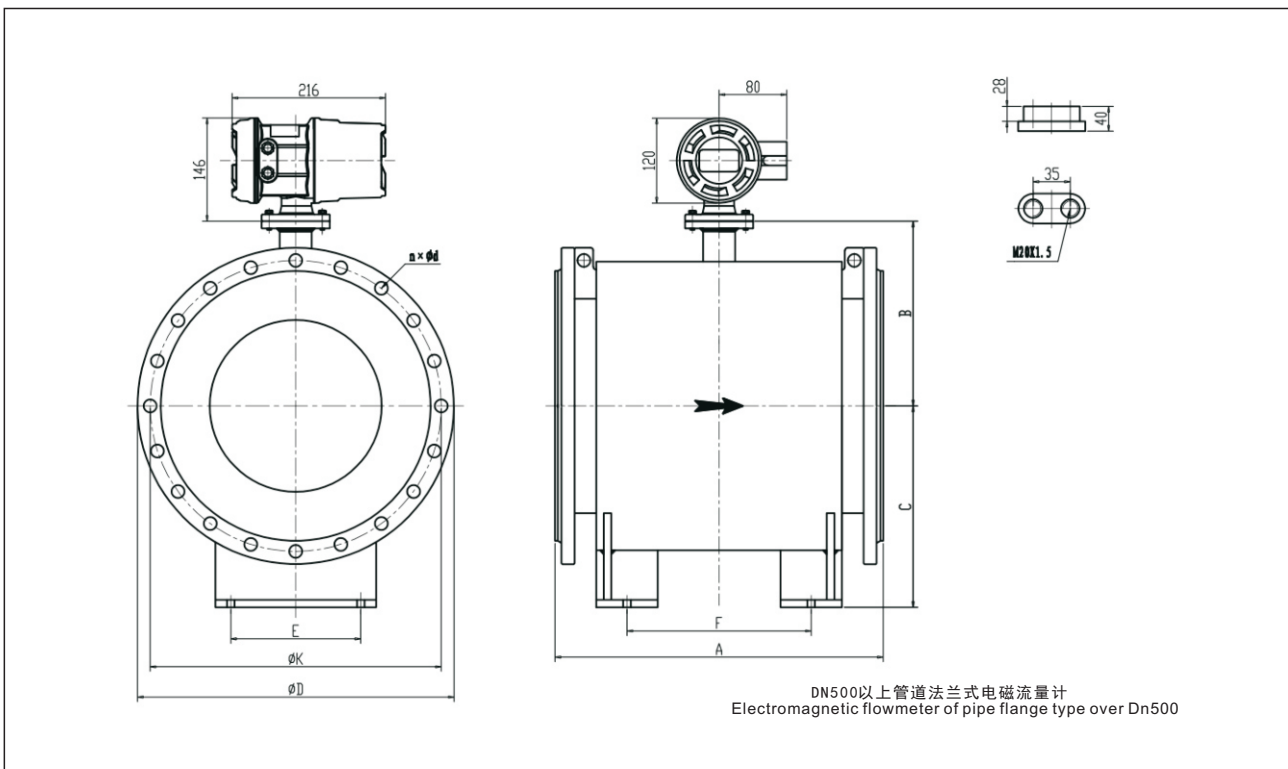
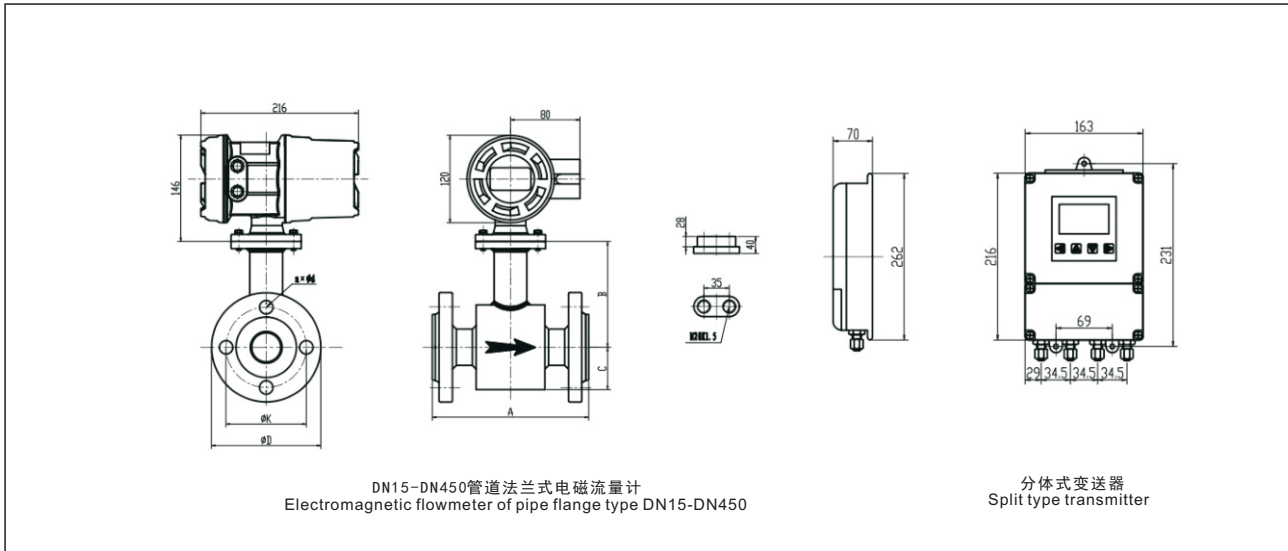

电磁流量计尺寸表图 Dimension table of electromagnetic flowmeter

管道法兰式 Pipeline flange type

DN	额定压力 Rated pressure	仪表外形尺寸 单位: mm Overall dimension of instrument									
	Mpa	A	B	C	E	F	φD	φK	n × φ 12		
10	4.0	150	90	50			90	60	4 × φ 14		
15		200		95			53	95	65	4 × φ 14	
20							62	105	75	4 × φ 18	
25				100			62	115	85	4 × φ 18	
32				105			72	140	100	4 × φ 18	
40				110			72	150	110	4 × φ 18	
50				121			72	165	125	4 × φ 18	
65				130			82	185	145	8 × φ 18	
80				135			89	200	160	8 × φ 18	
100				1.6			250	145	99	220	180
125	161				115	250		210	8 × φ 18		
150	300	171	130		285	240	8 × φ 22				
200	1.0	350	199	158			340	295	8 × φ 22		
250		450	224	185			395	350	12 × φ 22		
300		500	249	210			445	400	12 × φ 22		
350		550	274	241			505	460	16 × φ 22		
400		600	305	269			565	515	16 × φ 26		
450		600	330	294			615	656	20 × φ 26		
500		600	360	321			300	240	670	620	20 × φ 26
600		600	410	374				270	780	725	20 × φ 30
700		700	467	560			400	350	895	840	24 × φ 30
800		800	517	610				400	1010	950	24 × φ 33
900	900	567	660	470	1110	1050		28 × φ 33			
1000	1000	617	712	570	1225	1160		28 × φ 36			
1200	0.6	1200	719	814	600	710	1400	1340	32 × φ 33		
1400		1400	819	914		900	1625	1560	36 × φ 36		
1600		1600	919	1036	800	1040	1825	1760	40 × φ 36		
1800		1800	1021	1138		1180	2045	1970	44 × φ 39		
2000		2000	1121	1238		1350	2265	2180	48 × φ 42		

DN3~DN8电磁流量计外形尺寸及安装方式请联系天康工程师洽询。
Please contact Tiankang engineer about overall dimension and installation of DN3~DN8 electromagnetic flowmeter.

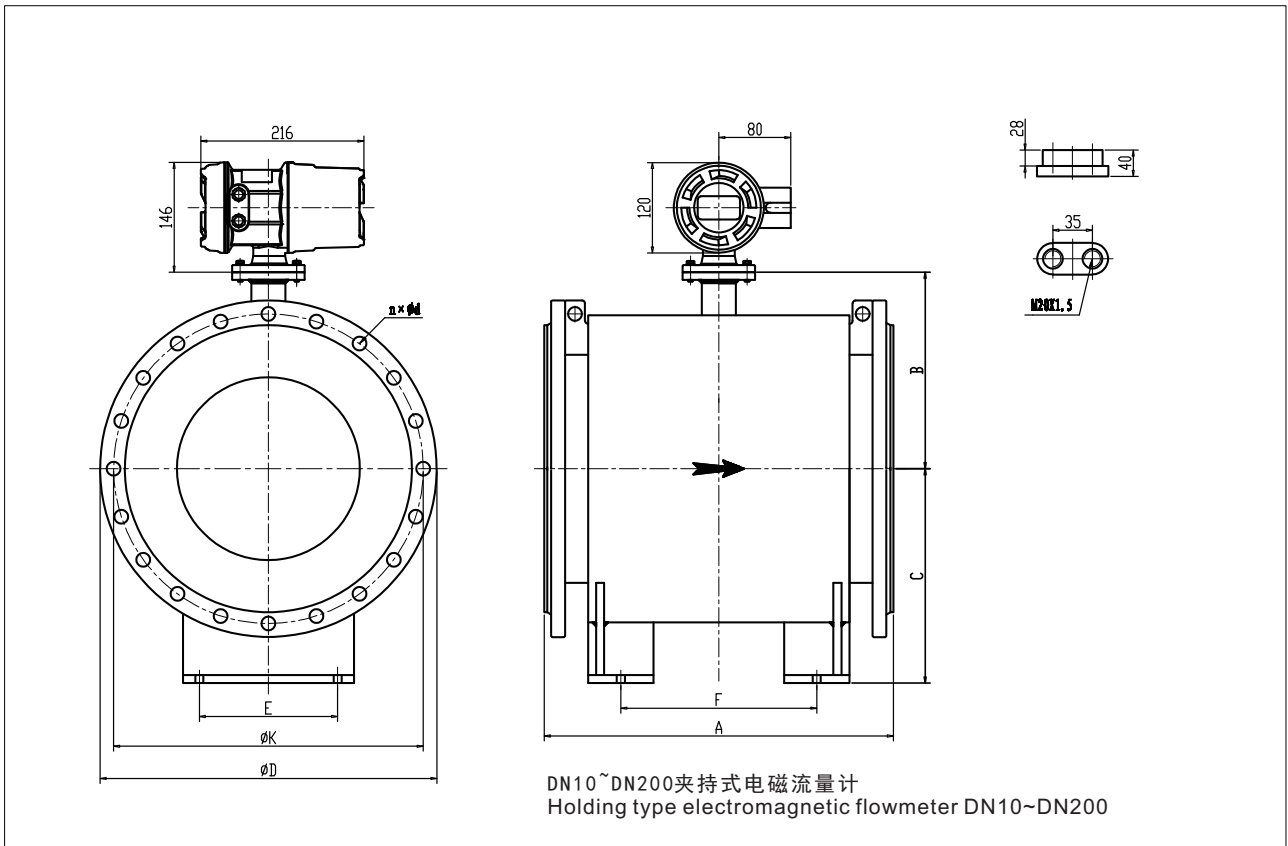

夹持式电磁流量计外形尺寸

Overall dimension of clamping type electromagnetic flowmeter

公称通径(MM) Nominal diameter	DN10	DN15	DN20	DN25	DN32	DN40	DN50	DN65	DN80	DN100	DN125	DN150	DN200
L(mm)	80	80	80	80	80	80	120	120	120	120	140	160	220

联系人: 姚经理: 13685509377 Email: 115192082@qq.com

1. 一体型端子接线图 Integrated type of terminal wiring diagram

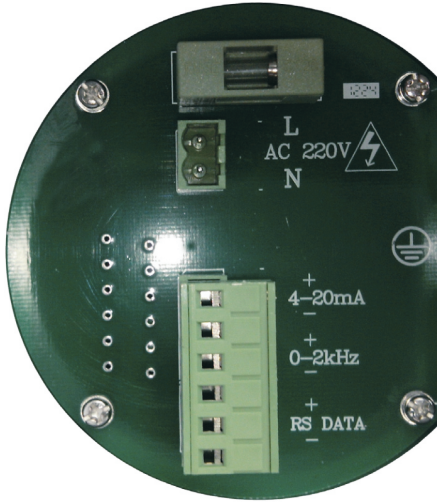

一体型接线端子标示定义
Definition of marking of integrated wiring terminal

序号No.	标示 Marking	功能 Function	备注 Note
L	L	AC 85~265V供电 AC 85~265V power supply	L为AC220V供电 L is the AC220V power supply
N	N	AC 85~265V供电 AC 85~265V power supply	N为AC220V供电 N is the AC220V power supply
+	+	DC 18~36V供电 + DC 18~36V power supply +	电源24V+ Power supply 24V+
-	-	DC 18~36V供电 + DC 18~36V power supply +	电源24V- Power supply 24V-
1	+	4~20mA输出+ 4~20mA output +	负载电阻 ≤500 Ω, Hart 通讯时, 采用外部24VDC供电 during Hart communication, external 24VDC power supply is adopted
2	-	4~20mA输出- 4~20mA output -	
3	+	频率或脉冲输出+ frequency or pulse output +	频率或脉冲输出的幅值为+24V, 负载电流 ≤50mA The amplitude value of the frequency or pulse output is +24V, load current ≤50mA.
4	-	频率或脉冲输出- frequency or pulse output -	
5	+	RS-485 Data +	
6	-	RS-485 Data -	

2. 分体型端子接线图 Split type of terminal wiring diagram

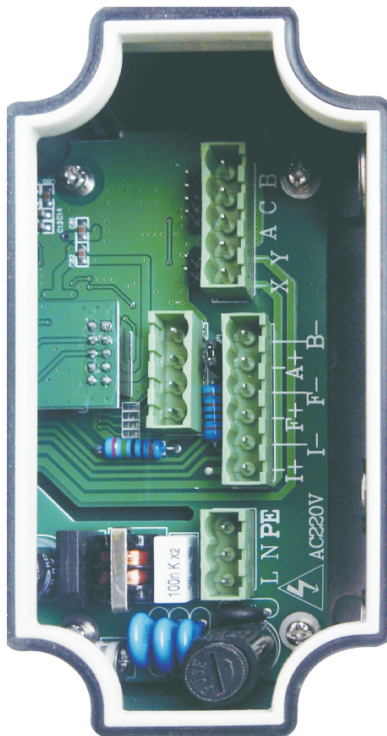

分体型各接线端子标示定义
Split type of terminal mark definition

序号No.	标示 Marking	功能 Function	备注 Note
L	L	AC 85~265V供电 AC 85~265V power supply	L为AC220V供电 L is the AC220V power supply
N	N	AC 85~265V供电 AC 85~265V power supply	N为AC220V供电 N is the AC220V power supply
+	+	DC 18~36V供电 + DC 18~36V power supply +	电源24V+ Power supply 24V+
-	-	DC 18~36V供电 + DC 18~36V power supply +	电源24V- Power supply 24V-
1	+	4~20mA输出+ 4~20mA output +	负载电阻 ≤500 Ω, Hart 通讯时, 采用外部24VDC供电 during Hart communication, external 24VDC power supply is adopted
2	-	4~20mA输出- 4~20mA output -	
3	+	频率或脉冲输出+ frequency or pulse output +	频率或脉冲输出的幅值为+24V, 负载电流 ≤50mA The amplitude value of the frequency or pulse output is +24V, load current ≤50mA.
4	-	频率或脉冲输出- frequency or pulse output -	
5	+	RS-485 Data +	
6	-	RS-485 Data -	
1	X	励磁驱动 X excitation drive X	负载电阻 10~100Ω load resistance 10~100Ω
2	Y	励磁驱动 Y excitation drive Y	
3	A	输入信号 A input signal A	
4	B	输入信号公共端 public input signal terminal	
5	C	输入信号 B input signal B	

面板结构示意图 Schematic diagram for panel structure

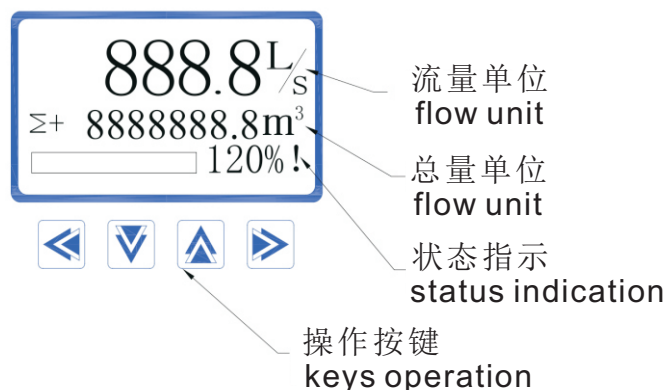

操作按键定义 Meaning of keys operation

- 设置参数确认和退出子菜单设置键
Parameter setting and exit sub-menu .
- 设置项"下移"和数据变量"递减"键（下移键）
"down"key for setting items and "decline" key for data (down key)
- 设置项"上移"和数据变量"递增"键（上移键）
"up" key for setting items and "increase"key for data(up key)
- 参数设置进入键，数据"右移"键（右移键）快捷键和组合键
Enter key for parameter setting, "right" key for data (right key)
Shortcut key and combinations key
- 和 快速系统零点校准，先按 键再按 键
 fast system zero calibration, press first,then press
- 和 先按住 键，再单击 键，将降低显示的灰度
 press first , then press , it will reduce the display of gray
- 和 先按住 键，再单击 键，将提升显示的灰度
单按 和 可进行显示屏对比度的提升或降低

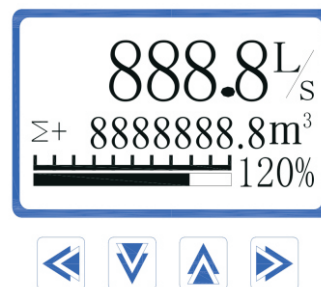

菜单目录结构树 Structure of menu contents

基本组态
Basic



1. 流量单位 PV Units
2. 流量显示分辨率 PV Decimal
3. 总量单位 Total Units
4. 总量显示分辨率 Total Decimal
5. 阻尼时间 (s) Damping(s)

系统组态
System

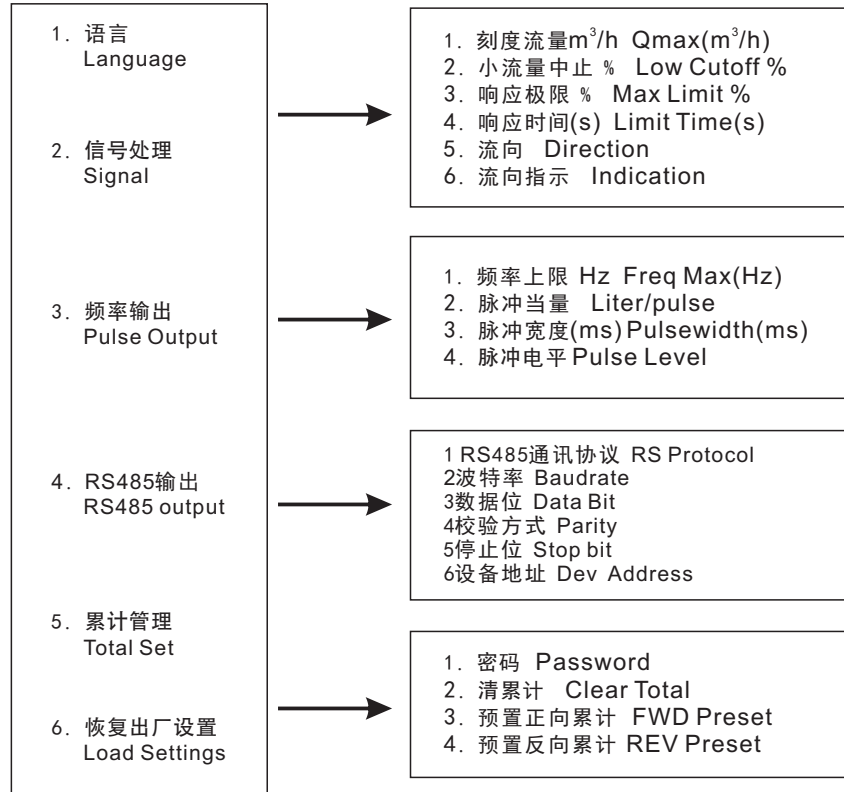

仪表校准
Calibration

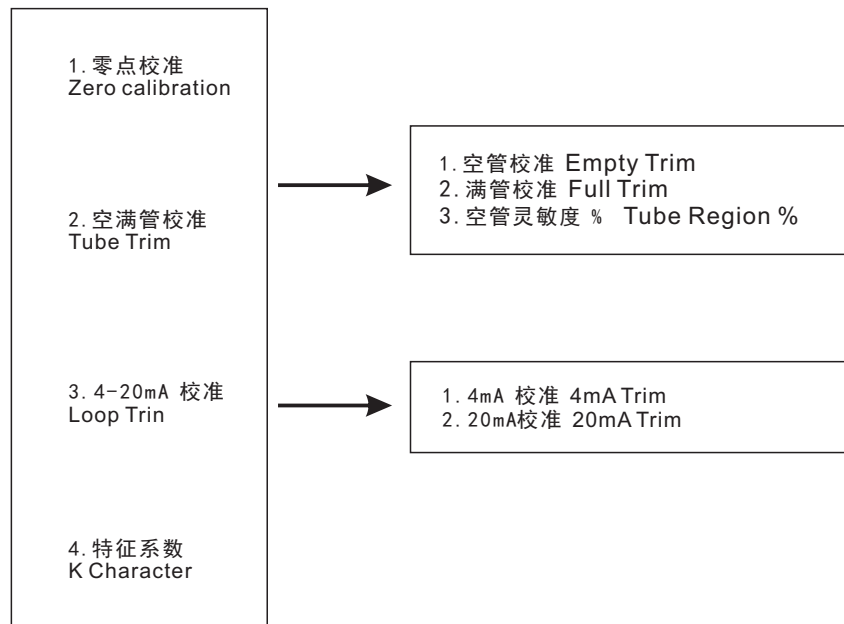

联系人：姚经理：13685509377 Email: 115192082@qq.com

仪表校准
Test



- 1. 4-20mA检验 Loop Test
- 2. 频率输出检验 Pulse Test

菜单显示结构 Menu display structure

(1) 测量模式下进入参数设置
按“→”键：出现如图界面，选择
“→”则进入菜单：
基本组态 Basic
系统组态 System
仪表校准 Calibration
仪表校验 Test

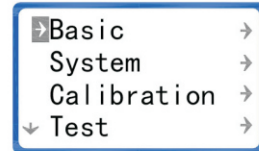

基本组态 Basic
1. 流量单位 PV Units
2. 流量显示分辨率 PV Decimal
3. 总量单位 Total Units
4. 总量显示分辨率 Total Decimal
5. 阻尼时间 (s) Damping(s)

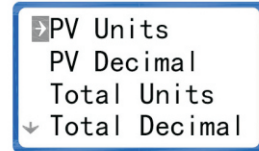
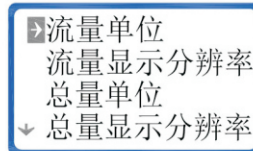

系统组态 System
1. 密码 Password
2. 语言 Language
3. 信号处理 Signal
4. 频率输出 Pulse Output
5. RS485输出 RS485 Output
6. 累计管理 Total Set
7. 恢复出厂设置 Load Settings

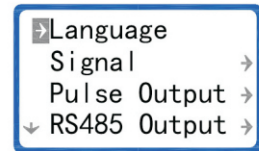
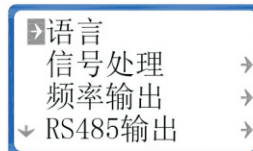

仪表校准 Calibration
1. 零点校准 Zero Trim
2. 空满管校准 Tube Trim
3. 4-20mA 校准 Loop Trin
4. 特征系数 K Character

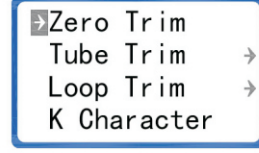
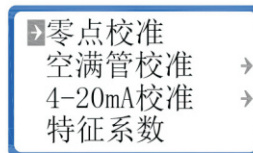

仪表检验 Test
1. 4-20mA检验 Loop Test
2. 频率输出检验 Pulse Test

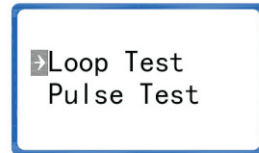
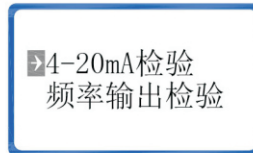

联系人：姚经理：13685509377 Email: 115192082@qq.com

TK1100系列标准型电磁流量计选型编码说明 Description of standard type for TK1100 series

TK1100系列电磁流量计DN3-DN2200
TK1100 series electromagnetic flowmeter DN3-DN2200
精度 ≤0.5% accuracy ≤0.5%

型号 Model	TK1100																			
安装方式 Installation method																				
法兰型 Flange type		F																		
夹持型 Holding type		W																		
衬里 Lining																				
硬橡胶 (Dn>50) Hard rubber (DN>50)			H																	
软橡胶 (DN>40) Soft rubber (DN>40)			S																	
聚氨酯 (DN>50~300) Polyurethane (DN>50~300)			E																	
PTFE (DN>20)			T																	
F46			F																	
PFA (DN>10~150)			P																	
PO (DN>50)			Z																	
口径																				
DN3																				03
DN6																				06
DN8																				08
DN10																				10
DN15																				15
DN20																				20
DN25																				25
DN32																				32
DN40																				40
DN50																				50
DN65																				65
DN80																				80
DN100																				1H
DN125																				1Q
DN150																				1F
DN200																				2H
DN250																				2F
DN300																				3H
DN350																				3F
DN400																				4H
DN450																				4F
DN500																				5H
DN600																				6H
DN700																				7H
DN800																				8H
DN900																				9H
DN1000																				1T
DN1200																				2M
DN1400																				4M
DN1600																				6M
DN1800																				8M
DN2000																				0M
DN2200																				P2

型号 Model	TK1100																		
电极材料 Electrode material	接地电极材料 Grounding electrode material																		
316L	／无 No		S																
哈氏合金B2 Hastelloy alloy B2	／无 No		B																
哈氏合金C4 Hastelloy alloy C4	／无 No		H																
钛 Titanium	／无 No		M																
钽 Tantalum	／无 No		T																
铂铱 Platinum iridium	／无 No		P																
碳化钨 Tantalum	／无 No		U																
316L	／有 Yes		E																
哈氏合金B2 Hastelloy alloy B2	／有 Yes		N																
哈氏合金C4 Hastelloy alloy C4	／有 Yes		J																
钛 Titanium	／有 Yes		A																
钽 Tantalum	／有 Yes		Q																
铂铱 Platinum iridium	／有 Yes		G																
碳化钨 Tantalum	／有 Yes		V																
额定压力 Rated pressure	0.6Mpa		B																
	1.0Mpa		C																
	1.6Mpa		D																
	2.5Mpa		E																
	4.0Mpa		F																
	其它 other		Z																
本体法兰材料 Flange material	配对法兰 Companion flange																		
无(夹持式) None(clamping type)	0	无(夹持式) None(clamping type)	0																
碳钢 Carbon steel	1	碳钢 Carbon steel	1																
304不锈钢 304 Stainless steel	2	304不锈钢 304 Stainless steel	3																
316不锈钢 316 Stainless steel	3	316不锈钢 316 Stainless steel	5																
其他 Other	4	其他 Other	7																
接地环 Grounding ring	无 No			A															
	接地环 Grounding ring			C															
温度范围 Grounding ring	标准温度 <70°C Standard temperature <70°C			0															
	标准温度 <130°C Standard temperature <130°C			1															
	标准温度 <160°C Standard temperature <160°C			2															
转换器形式 Converter form	一体 Integrated type			T															
	分体 Split type			R															
输出模式 Output mode	4-20mA + 脉冲			01															
	4-20mA + HART 通讯			02															
	4-20mA + Modbus 协议			03															
	4-20mA + Profibus 协议			04															
供电电源 Power supply	220VAC			G															
	24VDC			K															
防护等级 Protection level	Ip65			0															
	Ip67			1															
	Ip68			2															
防爆等级 Explosion proof grade	无 No			0															
	隔爆 Explosion suppression			EX															

说明：以上为标准型电极，刮刀（RE）、可更换（WE）请标明；一体型防护等级为IP65，分体可选IP67，IP68（仅传感器）
Note: The above is a standard type electrode, scraper (RE), can be replaced (WE) please mark;
The protection level of integrated type is IP65, and IP67 or IP68 (only sensor) can be selected for split type.

TK1200系列高精度电磁流量计选型编码说明 Description of high accuracy type for TK1200 series

TK1200系列电磁流量计DN10-DN300
Tk1200 series electromagnetic flowmeter DN10-DN1200
精度 ≤ 0.2% accuracy ≤ 0.2%

型号Model	TK1200																						
安装方式 Installation method 法兰型 Flange type 夹持型 Holding type		F																					
衬里 Lining 硬橡胶 (DN>50) Hard rubber(DN>50) 软橡胶 (DN>40) Soft rubber(DN>40) 聚氨酯 (DN>50~300) Polyurethane(DN>50~300) PTFE(DN>20) F46 PFA(DN>10~150) PO(DN>50)		H	S	E	T	F	P	Z															
口径 DN10 DN15 DN20 DN25 DN32 DN40 DN50 DN65 DN80 DN100 DN125 DN150 DN200 DN250 DN300									10	15	20	25	32	40	50	65	80	1H	1Q	1F	2H	2F	3H

联系人: 姚经理: 13685509377 Email: 115192082@qq.com

型号 Model	TK1200																		
电极材料 Electrode material	接地电极材料 grounding electrode material																		
316L	／无No		S																
哈氏合金B2 Hastelloy alloy B2	／无No		B																
哈氏合金C4 Hastelloy alloy C4	／无No		H																
钛 Titanium	／无No		M																
钽 Tantalum	／无No		T																
铂铱 Platinum iridium	／无No		P																
碳化钨 Tantalum	／无No		U																
316L	／有Yes		E																
哈氏合金B2 Hastelloy alloy B2	／有Yes		N																
哈氏合金C4 Hastelloy alloy C4	／有Yes		J																
钛 Titanium	／有Yes		A																
钽 Tantalum	／有Yes		Q																
铂铱 Platinum iridium	／有Yes		G																
碳化钨 Tantalum	／有Yes		V																
额定压力Rated pressure	0.6Mpa		B																
	1.0Mpa		C																
	1.6Mpa		D																
	2.5Mpa		E																
	4.0Mpa		F																
	其它other		Z																
本体法兰材料 Flange material	配对法兰 Companion flange																		
无(夹持式) None(clamping type)	0	无(夹持式) None(clamping type)	0																
碳钢 Carbon steel	1	碳钢 Carbon steel	1																
304不锈钢 304 Stainless steel	2	304不锈钢 304 Stainless steel	3																
316不锈钢 316 Stainless steel	3	316不锈钢 316 Stainless steel	5																
其他 Other	4	其他 Other	7																
接地环 Grounding ring	无 No			A															
	接地环 grounding ring			C															
温度范围 Grounding ring	标准温度 <70°C Standard temperature <70°C			0															
	标准温度 <130°C Standard temperature <130°C			1															
	标准温度 <160°C Standard temperature <160°C			2															
转换器形式 Converter form	一体 integrated type			T															
	分体 split type			R															
输出模式 Output mode	4-20mA + 脉冲			01															
	4-20mA + Pulse																		
	4-20mA + HART 通讯			02															
	4-20mA + HART communication																		
	4-20mA + Modbus 协议			03															
	4-20mA + Modbus protocol																		
	4-20mA + Profibus 协议			04															
	4-20mA + Profibus protocol																		
供电电源 Power supply	220VAC			G															
	24VDC			K															
防护等级 Protection level	Ip65			0															
	Ip67			1															
	Ip68			2															
防爆等级 Explosion proof grade	无 No			0															
	隔爆 explosion suppression			EX															

说明：以上为标准型电极，刮刀（RE）、可更换（WE）请标明；一体型防护等级为IP65，分体可选IP67，IP68（仅传感器）
 Note: The above is a standard type electrode, scraper (RE), can be replaced (WE) please mark;
 The protection level of integrated type is IP65, and IP67 or IP68 (only sensor) can be selected for split type.

TK1300系列卫生型电磁流量计选型编码说明 Description of hygienic type for TK1300 series

TK1300系列电磁流量计DN3-DN150
TK1300series electromagnetic flowmeter DN3-DN150
精度accuracy ≤0.2%; ≤0.5%

型号 Model	TK1300												
工艺接头 Process joints 三卡箍(3A) Three-clamps DIN11851 其它 Other	T	R	F										
衬里 Lining PTFE F46 PFA	T	F	P										
口径 DN3 DN6 DN10 DN15 DN20 DN25 DN32 DN40 DN50 DN65 DN80 DN100 DN125													03 06 10 15 20 25 32 40 50 65 80 1H 1Q
电极材料 Electrode material 316L 哈氏合金B2 Hastelloy alloy B2 哈氏合金C4 Hastelloy alloy C4	接地电极材料 grounding electrode material / 无No / 无No / 无No								S B H				
钛 Titanium 钽 Tantalum 铂铱 Platinum iridium	/ 无No / 无No / 无No								M T P				
316L 哈氏合金B2 Hastelloy alloy B2 哈氏合金C4 Hastelloy alloy C4	/ 有Yes / 有Yes / 有Yes								E N J				
钛 Titanium 钽 Tantalum 铂铱 Platinum iridium	/ 有Yes / 有Yes / 有Yes								A Q G				
温度范围 Grounding ring	标准温度<90℃ Standard temperature <90℃ 高温<160℃ High temperature <160℃								1 3				
转换器形式 Converter form	一体 Integrated type 分体 Split type								T R				
供电电源 Power supply	220VAC 24VDC								G K				
输出模式 Output mode	4-20mA + 脉冲 4-20mA + pulse 4-20mA + HART 通讯 4-20mA + HART communication 4-20mA + Modbus 协议 4-20mA + Modbus protocol 4-20mA + Profibus 协议 4-20mA + Profibus protocol												01 02 03 04
防护等级 Protection level	Ip65 Ip67 Ip68												0 1 2

TK1400插入式电磁流量计选型编码说明 Description of inserted type for TK1400 series

TK1400系列电磁流量计DN250-DN3000
TK1400 series electromagnetic flowmeter DN250-DN3000
精度accuracy $\leq 1.5\%$

型号Model	TK1400																	
标准型 Standard type 在线插拔式 On line plug and unplug		B Z																
安装方式 Installation method 螺纹固定式 Screw thread fixed type 法兰固定式 Flange fixed type		M G																
衬里 Lining PTFE POM		T M																
口径 DN200 DN250 DN300 DN350 DN400 DN450 DN500 DN600 DN700 DN800 DN900 DN1000 DN1200 DN1400 DN1600 DN1800 DN2000 DN2200 DN2400 DN2500 DN2600 DN2800 DN3000			2H 2F 3H 3F 4H 4F 5H 6H 7H 8H 9H 1T 2M 4M 6M 8M 0M 2P 4P 5P 6P 8P 3Q															

联系人: 姚经理: 13685509377 Email: 115192082@qq.com

型号 Model	TK1400										
电极材料 Electrode material	316L 哈氏合金B2 Hastelloy alloy B2 哈氏合金C4 Hastelloy alloy C4 钛 Titanium	S B H M									
额定压力 Rated pressure	0.6Mpa 1.0Mpa 1.6Mpa	B C D									
法兰材料 Flange material	/	配对法兰 Companion flange	0								
不锈钢 Stainless steel	/	无 No	1								
不锈钢 Stainless steel	/	有 Yes									
温度范围 Grounding ring	标准温度 <60°C Standard temperature <60°C 高温 <100°C High temperature <100°C		0 1								
转换器形式 Converter form	一体 Integrated type 分体 Split type		T R								
输出模式 Output mode	4-20mA + 脉冲		01								
	4-20mA + Pulse										
	4-20mA + HART 通讯		02								
	4-20mA + HART communication										
	4-20mA + Modbus 协议		03								
4-20mA + Modbus protocol											
4-20mA + Profibus 协议		04									
4-20mA + Profibus protocol											
供电电源 Power supply	220VAC 24VDC		G K								
防护等级 Protection level	Ip65 Ip67 Ip68		0 1 2								
防爆等级 Explosion proof grade	无 No 隔爆 explosion suppression		0 EX								

说明：以上为标准型电极；一体型防护等级为IP65，分体可选IP67，IP68(仅传感器)

Note: The above is a standard type electrode;

The ingress protection of one type is IP65, and IP67 or IP68(only sensor) can be selected by split type.

联系人：姚经理：13685509377 Email: 115192082@qq.com

TK1500系列标准型电磁流量计选型编码说明
Description of battery powered type for TK1500 series

TK1500系列电磁流量计DN10-DN1200
 TK1500 series electromagnetic flowmeter DN10-DN1200
 精度 ≤0.5%
 accuracy ≤0.5%

型号Model	TK1500													
安装方式 Installation method 法兰型 Flange type 夹持型 Holding type		F W												
衬里 Lining 硬橡胶 (Dn>50) Hard rubber(DN>50) 软橡胶 (DN>40) Soft rubber(DN>40) 聚氨酯 (DN>50~300) Polyurethane(DN>50~300) PTFE(DN>20) F46 PFA(DN>10~150) PO(DN>50)		H S E T F P Z												
口径 DN10 DN15 DN20 DN25 DN32 DN40 DN50 DN65 DN80 DN100 DN125 DN150 DN200 DN250 DN300 DN350 DN400 DN450 DN500 DN600 DN700 DN800 DN900 DN1000 DN1200			10 15 20 25 32 40 50 65 80 1H 1Q 1F 2H 2F 3H 3F 4H 4F 5H 6H 7H 8H 9H 1T 2M											

联系人: 姚经理: 13685509377 Email: 115192082@qq.com

型号 Model	TK1500																		
电极材料 electrode material	接地电极材料 grounding electrode material																		
316L	／无No	S																	
哈氏合金B2 Hastelloy alloy B2	／无No	B																	
哈氏合金C4 Hastelloy alloy C4	／无No	H																	
钛 Titanium	／无No	M																	
钽 Tantalum	／无No	T																	
铂铱 Platinum iridium	／无No	P																	
碳化钨 Tantalum	／无No	U																	
316L	／有Yes	E																	
哈氏合金B2 Hastelloy alloy B2	／有Yes	N																	
哈氏合金C4 Hastelloy alloy C4	／有Yes	J																	
钛 Titanium	／有Yes	A																	
钽 Tantalum	／有Yes	Q																	
铂铱 Platinum iridium	／有Yes	G																	
碳化钨 Tantalum	／有Yes	V																	
额定压力 Rated pressure	0.6Mpa	B																	
	1.0Mpa	C																	
	1.6Mpa	D																	
	2.5Mpa	E																	
	4.0Mpa	F																	
	其它other	Z																	
本体法兰材料 Flange material	配对法兰 companion flange																		
无(夹持式) None(clamping type)	0	无(夹持式) None(clamping type)	0																
碳钢 Carbon steel	1	碳钢 Carbon steel	1																
304不锈钢 304 Stainless steel	2	304不锈钢 304 Stainless steel	3																
316不锈钢 316 Stainless steel	3	316不锈钢 316 Stainless steel	5																
其他 Other	4	其他 Other	7																
接地环 Grounding ring	无 No		A																
	接地环 grounding ring		C																
温度范围 Grounding ring	标准温度 <70°C Standard temperature <70°C		0																
	标准温度 <130°C Standard temperature <130°C		1																
	标准温度 <160°C Standard temperature <160°C		2																
转换器形式 Converter form	一体 Integrated type		T																
	分体 Split type		R																
输出模式 Output mode	频率 frequency 0-5kHz		05																
供电电源 Power supply	3.6V 锂电池 lithium battery		Y																
防护等级 Protection level	Ip65		0																
	Ip67		1																
	Ip68		2																
防爆等级 Explosion proof grade	无 No		0																
	隔爆 Explosion suppression		EX																

说明：以上为标准型电极，刮刀（RE）、可更换（WE）请标明；一体型防护等级为IP65，分体可选IP67，IP68（仅传感器）

Note: The above is a standard type electrode, Scraper (RE), can be replaced (WE) please mark; The protection level of integrated type is IP65, and IP67 or IP68 (only sensor) can be selected by split type.

联系人：姚经理：13685509377 Email: 115192082@qq.com

TK1600系列电磁(热能)流量计选型编码说明

Description of electromagnetic(heat energy) type for TK1600 series

TK1600系列电磁(热能)流量计DN15-DN1200

TK1600series electromagnetic (heat energy) flowmeter DN15-DN1200

精度 $\leq 1.0\%$

accuracy $\leq 1.0\%$

型号Model	TK1600																		
安装方式 Installation method																			
法兰型 Flange type																			
夹持型 Holding type																			
衬里 Lining																			
硬橡胶 (Dn>50)Hard rubber(DN>50)																			
软橡胶 (DN>40) Soft rubber(DN>40)																			
聚氨酯 (DN>50~300) Polyurethane(DN>50~300)																			
PTFE(DN>20)																			
F46																			
PFA(DN>10~150)																			
PO(DN>50)																			
口径																			
DN15																			
DN20																			
DN25																			
DN32																			
DN40																			
DN50																			
DN65																			
DN80																			
DN100																			
DN125																			
DN150																			
DN200																			
DN250																			
DN300																			
DN350																			
DN400																			
DN450																			
DN500																			
DN600																			
DN700																			
DN800																			
DN900																			
DN1000																			
DN1200																			

联系人: 姚经理: 13685509377 Email: 115192082@qq.com

型号 Model	TK1600										
电极材料 Electrode material	接地电极材料 grounding electrode material										
316L	/无NO S										
哈氏合金B2 Hastelloy alloy B2	/无NO B										
哈氏合金C4 Hastelloy alloy C4	/无NO H										
钛 Titanium	/无NO M										
钽 Tantalum	/无NO T										
铂铱 Platinum iridium	/无NO P										
碳化钨 Tantalum	/无NO U										
316L	/有Yes E										
哈氏合金B2 Hastelloy alloy B2	/有Yes N										
哈氏合金C4 Hastelloy alloy C4	/有Yes J										
钛 Titanium	/有Yes A										
钽 Tantalum	/有Yes Q										
铂铱 Platinum iridium	/有Yes G										
碳化钨 Tantalum	/有Yes V										
额定压力 Rated pressure	0.6Mpa B 1.0Mpa C 1.6Mpa D 2.5Mpa E 4.0Mpa F 其它 other Z										
本体法兰材料 Flange material	配对法兰 Companion flange										
无(夹持式) None(clamping type)	0 无 None 0										
碳钢 Carbon steel	1 碳钢 Carbon steel 1										
304不锈钢 304 Stainless steel	2 304不锈钢 304 Stainless steel 3										
316不锈钢 316 Stainless steel	3 316不锈钢 316 Stainless steel 5										
其他 Other	4 其他 Other 7										
接地环 Grounding ring	无 No A 接地环 grounding ring C										
温度范围 Grounding ring	标准温度 <70°C Standard temperature <70°C 0 标准温度 <130°C Sandard temperature <130°C 1 标准温度 <160°C Standard temperature <160°C 2										
转换器形式 Converter form	一体 Integrated type T 分体 Split type R										
输出模式 Output mode	4-20mA + 脉冲 01 4-20mA + Pulse 4-20mA + HART 通讯 02 4-20mA + HART communication 4-20mA + Modbus 协议 03 4-20mA + Modbus protocol 4-20mA + Profibus 协议 04 4-20mA + Profibus protocol										
供电电源 Power supply	220VAC G 24VDC K										
防护等级 Protection level	Ip65 0 Ip67 1 Ip68 2										
防爆等级 Explosion proof grade	无 No 0 隔爆 explosion suppression EX										

说明：以上为标准型电极，刮刀（RE）、可更换（WE）请标明；一体型防护等级为IP65，分体可选IP67，IP68（仅传感器）
 Note: The above is a standard type electrode, scraper (RE), can be replaced (WE) please mark;
 The protection level of integrated type is IP65, and IP67 or IP68(only sensor) can be selected for split type.

联系人：姚经理：13685509377 Email: 115192082@qq.com

电极材质防腐选用参考表

Reference table for anti-corrosion of electrode materials

符号说明：A-适用，B-可用，寿命短；N-不能用；X-耐腐蚀；空白-无数据；Sat-饱和。
 Symbol notes: A-applicable; B-available, shot life; N-not available; X-corrosion resistance;
 Blank-no date; Sat-saturation.

介质名称 Dielectric name	浓度% Concentratio	温度℃ Temperatur	316L	哈氏C Hastelloy C	钛 Titanium	钽 Tantalum	铂 Platinum	
硫酸 Sulfuric acid	2-5	室温 Room temperature	N	X	X	A	A	
		沸点 Boiling point	N	N	X	N	A	
	10	室温 Room temperature	N	X	X	A	A	
		沸点 Boiling point	N	N	N	N	A	
	25-60	室温 Room temperature	N	X	B	A	A	
		沸点 Boiling point	N	N	N	N	A	
	70-85	室温 Room temperature	N	X	N	A	A	
		沸点 Boiling point	N	N	N	N	A	
	90-96	室温 Room temperature	X	X	N	A	A	
		沸点 Boiling point	N	N	N	N	A	
	盐酸 Hydrochloric acid	0.5-5	室温 Room temperature	N	X	A	A	A
			沸点 Boiling point	N	N	A	X	X
10-20		室温 Room temperature	N	B	A	A	A	
		沸点 Boiling point	N	N	N	X	X	
37		室温 Room temperature	B	N	N	A	X	
		沸点 Boiling point	N	N	N	X	X	
硝酸 Nitric acid	7-65	室温 Room temperature	X	X	X	A	A	
		沸点 Boiling point	X	N	X	A	A	
	100	室温 Room temperature	N		X	A	A	
		沸点 Boiling point			X	A	A	
铬酸 Chromic acid	10	室温 Room temperature	A	A	A	A	A	
		沸点 Boiling point	N	A	A	A	N	
	50	室温 Room temperature	N	A	A	A	A	
		沸点 Boiling point	N	A	A	A	A	
	100	室温 Room temperature	N	N		A	A	
		沸点 Boiling point	N	N		A	A	

联系人：姚经理：13685509377 Email: 115192082@qq.com

介质名称 Dielectric name	浓度% Concentratio	温度℃ Temperatur	316L	哈氏C Hastelloy C	钛 Titanium	钽 Tantalum	铂 Platinum
王水 Aqua regia	100	室温 Room temperature	N	N	B	A	N
		沸点 Boiling point	N	N	N	N	A
氢氟酸 Hydrofluoric acid	1-50	室温 Room temperature	N	N	N	N	A
	98-100	沸点 Boiling point	N	N	N	N	A
磷酸 Phosphoric acid	1-30	室温 Room temperature	X	X	X	A	A
	45-Sat	室温 Room temperature	B	X	B	A	A
	80-Sat	沸点 Boiling point	N	N	N	A	A
乙酸 Acetic acid	5-10	室温 Room temperature	A	A	A	A	A
	50以上 more than 50	室温 Room temperature	N	A	A	A	A
	Sat	室温 Room temperature	A	A	A	X	A
甲醇 Methanol	100	室温 Room temperature	A	A	A	X	A
	100	沸点 Boiling point	B	A	B	X	A
污水 Wastewater		室温 Room temperature	A	A	A	A	A
海水 Seawater		室温 Room temperature	B	A	A	A	A
甲酸 Formic acid	10-15	室温 Room temperature	N	A	A	A	A
		沸点 Boiling point	N	B	A	A	A
	50-100	室温 Room temperature	N	B	B	A	A
		沸点 Boiling point	N	N	N	A	A
草酸 Oxalic acid	5-10	室温 Room temperature	A	A	A	X	A
	25-50	沸点 Boiling point		A	A	X	A
	Sat	室温 Room temperature		N	B	X	A
	5-Sat	沸点 Boiling point	N	N	N	X	A
柠檬酸 Citric acid	5-25	室温 Room temperature	A	A	A	X	A
		沸点 Boiling point	A	A	A	X	A
		室温 Room temperature	A	A	A	X	A
		沸点 Boiling point	A	A	B	X	B
氯化铁 Ferric chloride	10-Sat	室温 Room temperature	N	A	A	A	N
氯化钠 Sodium chloride	100	室温 Room temperature	B	A	A	X	A
		沸点 Boiling point	B	A	A	X	A

联系人：姚经理：13685509377 Email: 115192082@qq.com

介质名称 Dielectric name	浓度% Concentratio	温度℃ Temperatur	316L	哈氏C Hastelloy C	钛 Titanium	钽 Tantalum	铂 Platinum
氯化铵 Ammonium chloride	10-20	室温 Room temperature	N	B	B	A	A
		沸点 Boiling point	N	B	B	A	A
	50-100	室温 Room temperature	N	B	B	X	A
		沸点 Boiling point	N	B	B	X	A
氯化钙 Calcium chloride	100	室温 Room temperature	N	N		A	A
		沸点 Boiling point		X		A	A
氯化镁 Magnesium chloride	10-30	室温 Room temperature	N	B	B	A	A
		沸点 Boiling point	N	B		X	A
硝酸钾 Potassium nitrate	20-50	室温 Room temperature	A	A	A	X	A
		沸点 Boiling point	A	A	A	X	A
	80-Sat	室温 Room temperature	A	A	A	X	A
		沸点 Boiling point	N	A	A	X	A
硫酸钠 Sodium sulfate	Sat	室温 Room temperature	A	A	A	A	A
		沸点 Boiling point	N	N	N	A	A
脂肪酸 Fatty acids	100	室温 Room temperature	A	A	A	X	A
	100	沸点 Boiling point	B	A	A	X	A
乳酸 Lactic acid	1.5-10	室温 Room temperature	A	A	A	X	
	1.5-10	沸点 Boiling point	N	A	A	X	
	Sat	沸点 Boiling point	N	N	A	A	
硝酸铝 Aluminum nitrate	10	室温 Room temperature	A	X	A	A	A
	10-100	室温 Room temperature		X	A	X	
	57	120℃			X	A	X
纸浆 Paper pulp		室温 Room temperature	B	A	A	A	A
石灰浆 Calcium hydroxide		室温 Room temperature	N	B	A	A	A

联系人：姚经理：13685509377 Email: 115192082@qq.com

常见液体电导率参数表

Parameter table of liquid conductivity parameter table

介质名称 Dielectric name	浓度% Concentration	温度℃ Temperature	电导率(S/cm) Conductivity
硫酸 Sulfuric acid	5	18	20.85×10^{-2}
	85		98.50×10^{-3}
	99.4		85.00×10^{-4}
盐酸 Hydrochloric acid	5	15	39.48×10^{-2}
	40		51.52×10^{-2}
硝酸 Nitric acid	6.2	18	31.23×10^{-2}
	31		79.19×10^{-2}
	62		49.04×10^{-2}
氢氟酸 Hydrofluoric acid	0.004	18	2.50×10^{-4}
	0.121		21.00×10^{-4}
	4.80		59.3×10^{-3}
	29.80		34.11×10^{-2}
醋酸 Acetic acid	0.30	18	3.18×10^{-4}
	20		16.05×10^{-4}
	70		2.35×10^{-4}
	99.70		4.00×10^{-8}
	100(纯)	25	1.20×10^{-8}
磷酸 Phosphoric acid	10	15	56.6×10^{-3}
	70		14.73×10^{-2}
	87		70.90×10^{-3}
氨水 Ammonium hydroxide	0.10	15	2.51×10^{-4}
	8.03		10.38×10^{-4}
	30.50		1.93×10^{-4}
丁酸 Butyric acid	1.00	18	4.55×10^{-4}
	50.04		2.96×10^{-4}
	70.01		5.6×10^{-7}
	100		6.0×10^{-8}
氢溴酸 Hydrobromic acid	5	15	19.08×10^{-2}
	15		49.40×10^{-2}
	100		8.0×10^{-4}
氯化钡 Barium chloride	5	18	3.89×10^{-2}
	24		15.34×10^{-2}
硫酸钾 Potassium sulphate	5	18	45.80×10^{-3}

介质名称 Dielectric name	浓度% Concentration	温度℃ Temperature	电导率(S/cm) Conductivity
甲酸 Formic acid	4.94	18	55.00×10^{-4}
	39.955		98.40×10^{-4}
	100		2.80×10^{-4}
	100(纯)		5.60×10^{-5}
草酸 Oxalic acid	3.5	18	5.08×10^{-2}
	5	18	67.20×10^{-3}
氯化钠 Sodium chloride	10		12.11×10^{-2}
	26		21.51×10^{-2}
氯化钙 Calcium chloride	5		6.43×10^{-2}
	25		17.81×10^{-2}
	35		13.66×10^{-2}
氯化铵 Ammonium chloride	5	18	91.80×10^{-3}
	25		40.25×10^{-2}
氯化钾 Potassium chloride	5	18	69.90×10^{-3}
	21		28.10×10^{-2}
氯化镁 Magnesium chloride	5	18	68.30×10^{-3}
	30		10.61×10^{-2}
硫酸钠 Sodium sulfate	5	18	40.90×10^{-3}
	15		88.60×10^{-3}
硫酸铜 Cupric sulfate	2.50	18	10.90×10^{-3}
	17.50		45.80×10^{-3}
硝酸钾 Potassium nitrate	5	15	45.4×10^{-3}
	22		16.25×10^{-2}
硫酸铵 Ammonium sulfate	5	15	55.20×10^{-3}
	31		23.21×10^{-2}
硝酸铵 Ammonium nitrate	5	15	55.20×10^{-3}
	50		23.21×10^{-2}
氯化锌 Zinc chloride	2.5	15	27.60×10^{-3}
	30		92.60×10^{-3}
	60		36.9×10^{-3}
碳酸钠 Sodium carbonate	5	18	45.10×10^{-3}
	15		83.60×10^{-3}
尿素 Urea	100	145	5.0×10^{-3}

联系人：姚经理：13685509377 Email：115192082@qq.com

组态数据表 Data table of configuration

客户名称 Client name :	日期 Date:		
联系人 Client name :	部门 Department:		
电 话TEL:	传真FAX:		
产品型号 Product model:	位号No.:		
测量介质 Measuring medium:	<input type="checkbox"/> 液体Liquid (是否带有固体颗粒with solid particles) <input type="checkbox"/> Yes <input type="checkbox"/> No		
电导率 conductivity:	是否大于 More than	5 μ s	<input type="checkbox"/> Yes <input type="checkbox"/> No
流量范围 Flow range:	最大Maximum	正常Normal	最小Minimum
工作压力 working pressure :	最大Maximum	正常Normal	最小Minimum
介质温度 working pressure :	最大Maximum	正常Normal	最小Minimum
工艺管径 working pressure :			
法兰材质 Flange material:	<input type="checkbox"/> 碳钢Carbon steel <input type="checkbox"/> 不锈钢Stainless steel		
转 换 器 converter:	<input type="checkbox"/> 一体One type <input type="checkbox"/> 分体 (电缆长度) Split type(cable length)		
供电电源 power supply:	<input type="checkbox"/> 220V AC <input type="checkbox"/> 24VDC		
防护等级 ingress protection:	<input type="checkbox"/> Ip65 <input type="checkbox"/> Ip68		
防爆要求 explosion proof requirement:	<input type="checkbox"/> Yes <input type="checkbox"/> No		
电气输出 electrical output:	<input type="checkbox"/> 脉冲Pulse <input type="checkbox"/> 4-20mA 电流Current		
	<input type="checkbox"/> HART <input type="checkbox"/> MODBUS <input type="checkbox"/> PROFIBUS		

联系人: 姚经理: 13685509377 Email: 115192082@qq.com